

A close-up photograph of a ZF6 transmission component, showing several black cylindrical shafts with blue and yellow caps. A computer monitor is superimposed over the center of the image, displaying the webinar title. A yellow banner with the word 'FREE' is positioned in the top left corner of the monitor.

**FREE**

**sonnax®**  
**WEBINAR**

ZF6 Gen. 1 & Gen. 2  
Identification & Repair Techniques

**sonnax®**

# WELCOME

- **Connections**
- **Handout**
- **Questions**
- **[steve.garrett@sonnax.com](mailto:steve.garrett@sonnax.com)**
  
- **Sonnax Tech Resources available free of charge at [www.sonnax.com](http://www.sonnax.com)**
- **Call for Tech Assistance: [1-800-843-2600](tel:1-800-843-2600)**

# Training Objectives

## Webinar Topics

### 1. ZF6 Overview:

- Fluid Type
- Apply Components
- Gen. 1 vs. Gen. 2 Introduction

### 2. ZF6 Solenoids:

- Normally Vented vs. Normally Applied
- Solenoid Function
- Identify Various Solenoids

### 3. ZF6 Identification

- Valve Body Differences
- ZF Terms

### 4. ZF6 Parts

### 5. Symptoms and Corrections

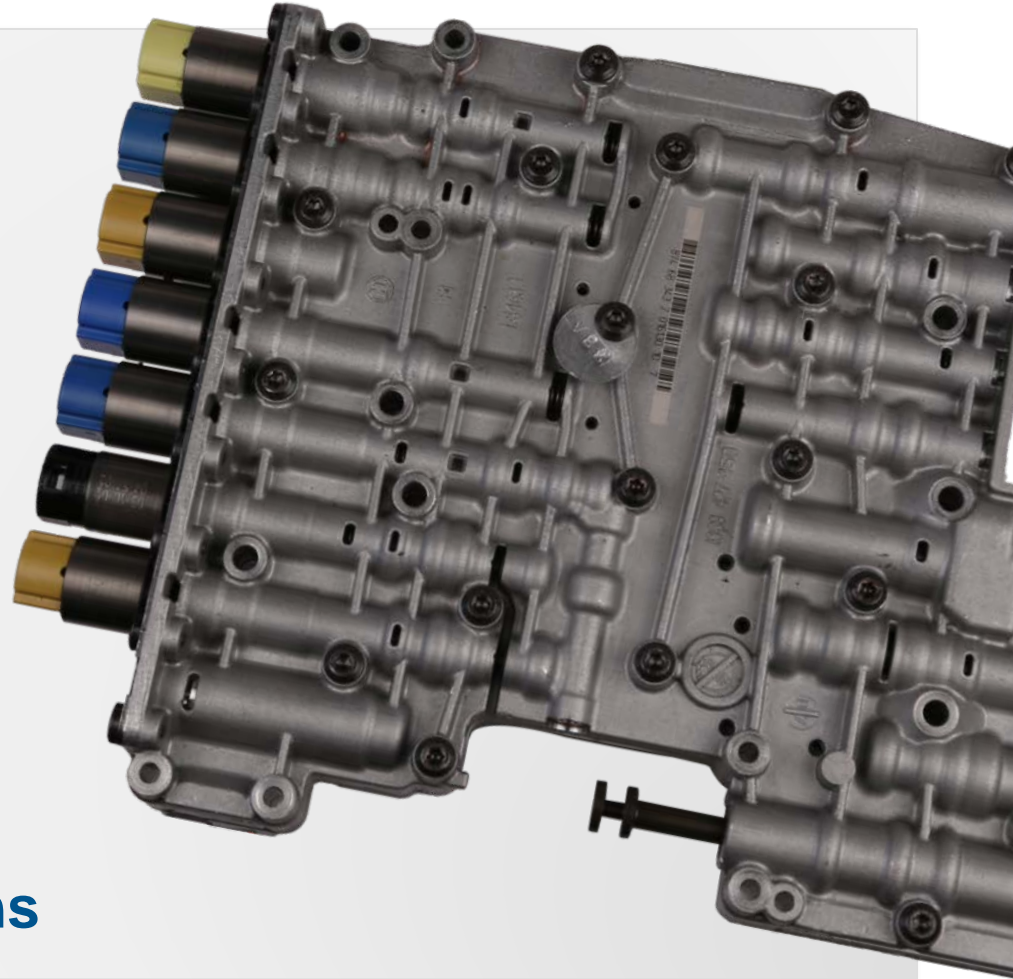

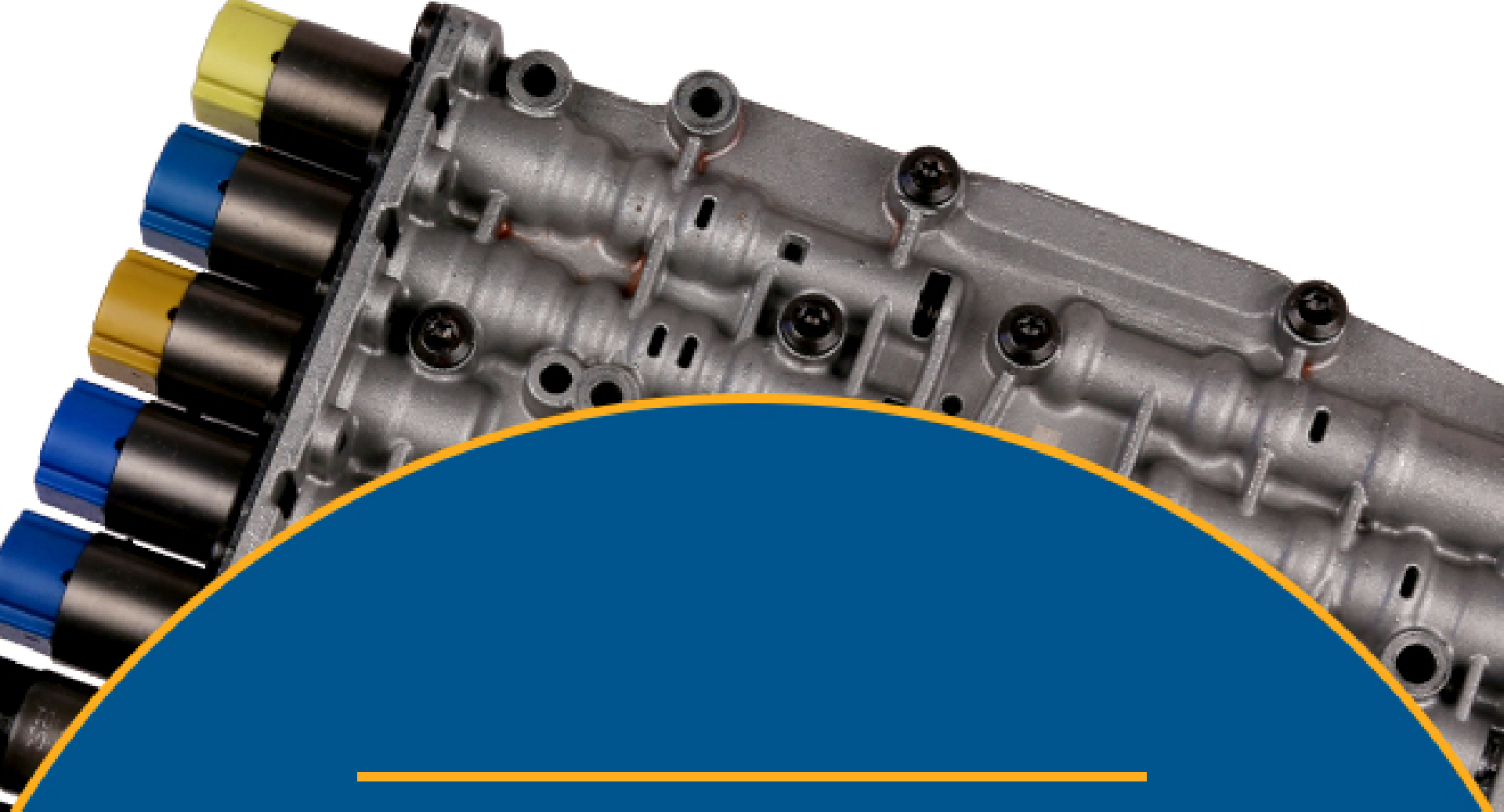

---

# ZF6 Overview

---

# ZF6 Overview

ZFS  
LU 7521139  
1068 012 **063ZA**



\* 0072473ZZA \* HW7521155

← Transmission part number



GETRIEBE-NR	0072473
SERIAL NO.	
STUECKL. 1068	010034
MODEL NO. ●	
6HP-26	

← Main parts list

← Serial number

Note: This Number may be embossed  
in the case or a metal tag

# ZF6 Overview

- **Five clutches:**
  - Three driving (A, B, E)
  - Two holding (brakes) (C, D)
- **Lepelletier planetary gear train**
- **A mechatronic module:**
  - Controls shift feel and shift timing
  - Mounted inside the transmission
  - A “CAN BUS” interface connects the transmission with the rest of the vehicle
- **7 to 9 Solenoids (based on application)**
- **Two versions (“E” and “M”):**
  - “E” version uses a park rod cylinder
  - “M” version utilizes a standard design manual valve configuration

# ZF6 Overview

- **Different fluid is required depending on application:**
  - 6HP19, 6HP21, 6HP26, 6HP28, 6HP32 (BMW, Jaguar, Ford, Maserati, Hyundai, Range Rover, Aston Martin, Rolls Royce, Bentley)
  - ZF Lifeguard 6 - Part # S671 090 281 (yellow color) - 6HP26A61
  - ZF Lifeguard 6 Plus - Part # S671 090 255 (Blue Color) - 6HP19A, 6HP28AF
  - ZF Lifeguard 8 - Part # AA00 601 304 (Green Color)
- **Two designs were produced:**
  - Generation 1 (6HP19, 6HP26, 6HP32)
  - Generation 2 (6HP21, 6HP28, 6HP34)
- **Major differences:**
  - Mechatronic module
  - Solenoid firing sequence
  - Valve bodies

# ZF6HP Fluid Type

All of the units listed are compatible with all the fluids listed in the column to the right.

- 6HP19
- 6HP19X (not for Audi Q7)
- 6HP21, 6HP21X, 6HP26, 6HP26X
- 6HP26A61 (not for Audi W12)
- 6HP28, 6HP28X, 6HP28A61
- 6HP32, 6HP32A, 6HP32X

The fluids listed are the same other than the manufacture part number.

- ZF lifeguard fluid 6 S671 090 255
- AML 4G4319A509/AA/S
- Audi /VW G 055005 A1 / A2 / A6
- Bentley PY112995PA
- BMW 8322 0142516
- Hyundai 040000C90SG
- Jaguar 8432
- Land Rover TYK500050
- Maserati 231603



# ZF6HP Fluid Type

All of the units listed are compatible with all the fluids listed in the column to the right.

- 6HP26A61 (Audi W12 engine)

The fluids listed are the same other than the manufacture part number.

- ZF lifeguard fluid 6 Plus  
S671 090 281
- Audi / VW G 055162 A1 / A2 / A6

All of the units listed are compatible with all the fluids listed in the column to the right.

- 6HP19A
- 6HP19X (for Audi Q7)
- 6HP28AF

The fluids listed are the same other than the manufacture part number.

- ZF lifeguard fluid 8 AA00 601 304
- Audi / VW 060162 A1 / A2 / A6

# ZF6HP Apply Components

Gear	1-2-3-4 (A Clutch)	3-5-R (B Clutch)	2-6 (C Clutch)	Low-Reverse (D Clutch)	4-5-6 (E Clutch)
Park				Applied	
Reverse		Applied		Applied	
Neutral				Applied	
1 <sup>st</sup>	Applied			Applied	
2 <sup>nd</sup>	Applied		Applied		
3 <sup>rd</sup>	Applied	Applied			
4 <sup>th</sup>	Applied				Applied
5 <sup>th</sup>					Applied
6 <sup>th</sup>		Applied	Applied		Applied

# Fluid Passages & Air Testing

"A" and "E" clutches are fed through the case and pump.

"B", "C", "D" clutches are fed through the case and center support.

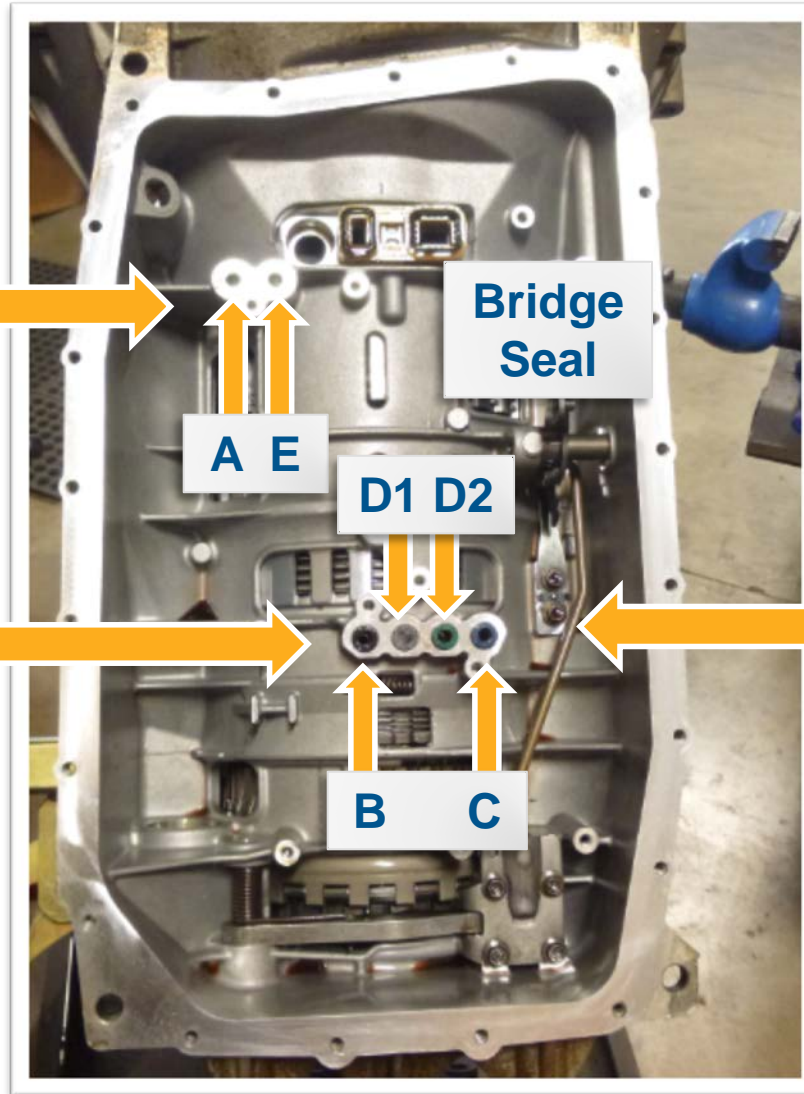

Like the bridge seal, the valve body tube seals need to be installed correctly. Make sure you are using the latest design for your application.

# Bridge Seal/Adapters

6HP19/21 and 6HP26/28/32 bridge seal adapters are different heights and not interchangeable:

- 6HP19/21 = 15.4 mm  $\pm$  0.1mm
- 6HP26/28/32 = 14.4 mm  $\pm$  0.1 mm tall

Late model adapters have a locating tab to prevent installation of the wrong adapter.

Unknown adapters can be identified by their height.

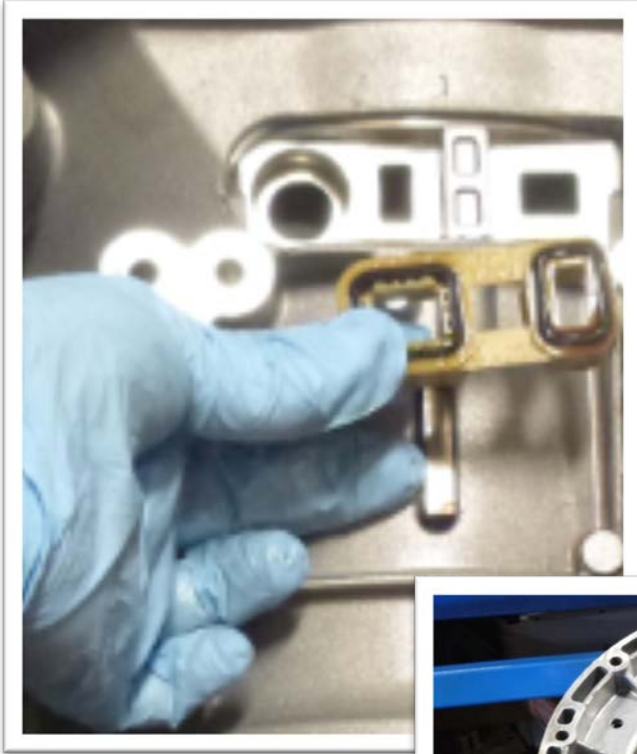

# Clutch Assemblies

"A" Clutch 1-2-3-4 and "E" Clutch 4-5-6

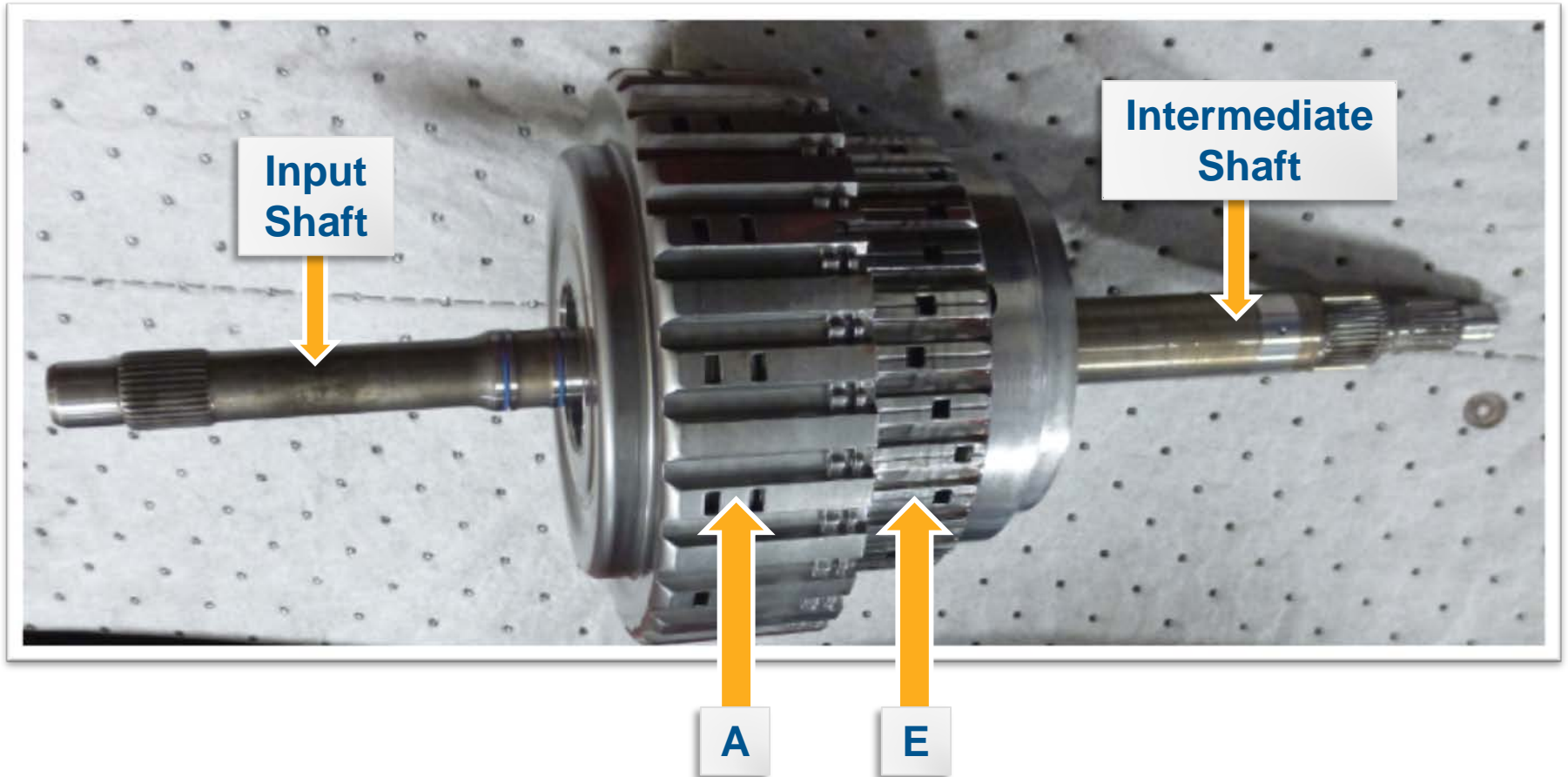

# Clutch Assemblies

"B" Clutch 3-5-Reverse



# Clutch Assemblies

“C” Clutch 2-6 and “D” Clutch Low Reverse, Center Support

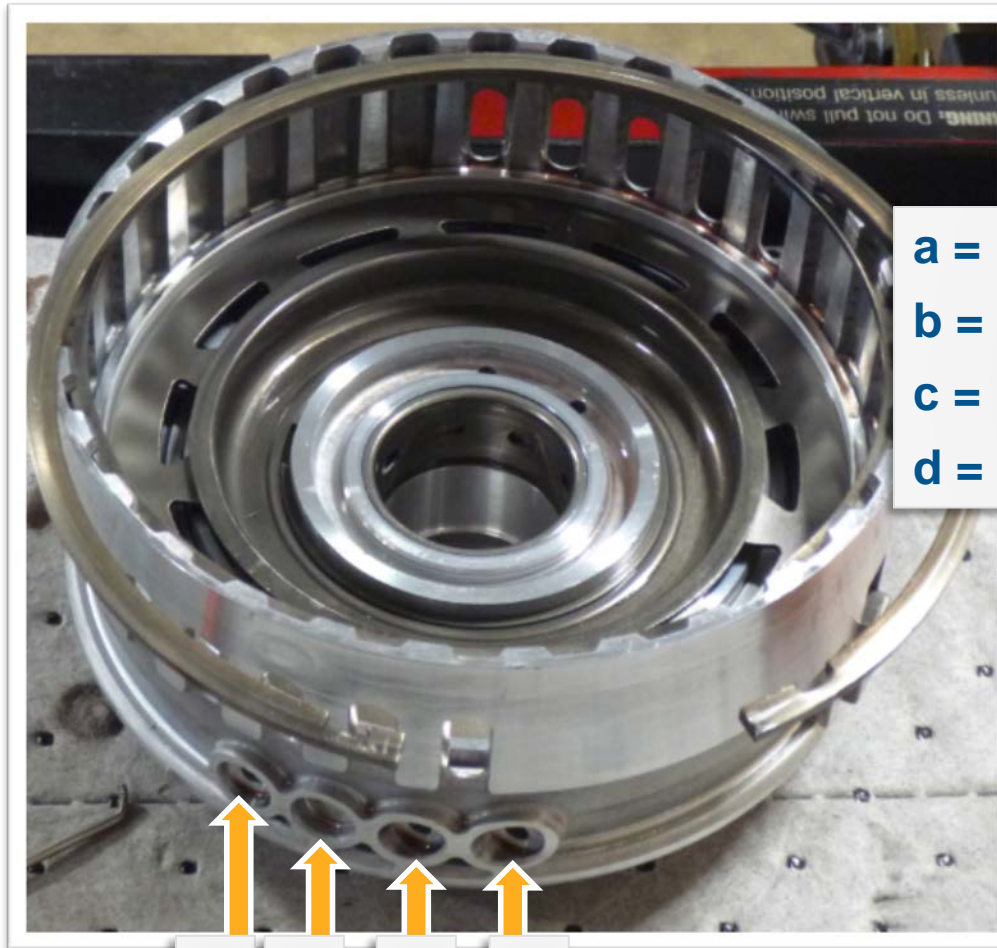

**a = B Clutch**

**b = D Clutch Reaction Piston**

**c = D Clutch Apply Piston**

**d = C Clutch**

**a**

**b**

**c**

**d**

# ZF6 Mechatronic - TCM and VB

- Must be programmed to operate:
  - Speed limited, 17mph (13kph) if not programmed
- Two temp sensors used:
  - If a temp sensor is out of range, 3<sup>rd</sup> or 5<sup>th</sup>
  - Default may occur
- No upshift, high line:
  - Ground issue, solenoid circuit problem
- Position sensor issues:
  - Contamination

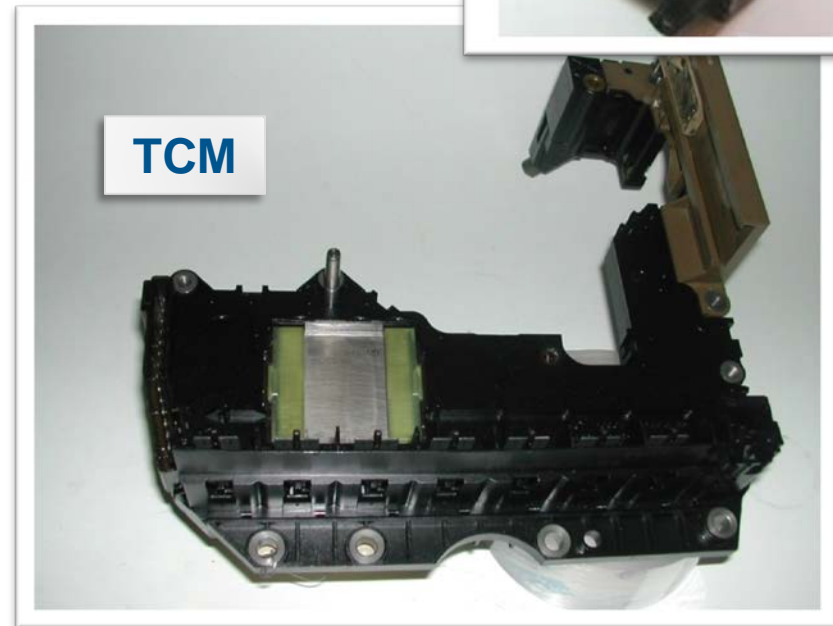



# ZF6 Generations

## Gen. 1 vs Gen. 2

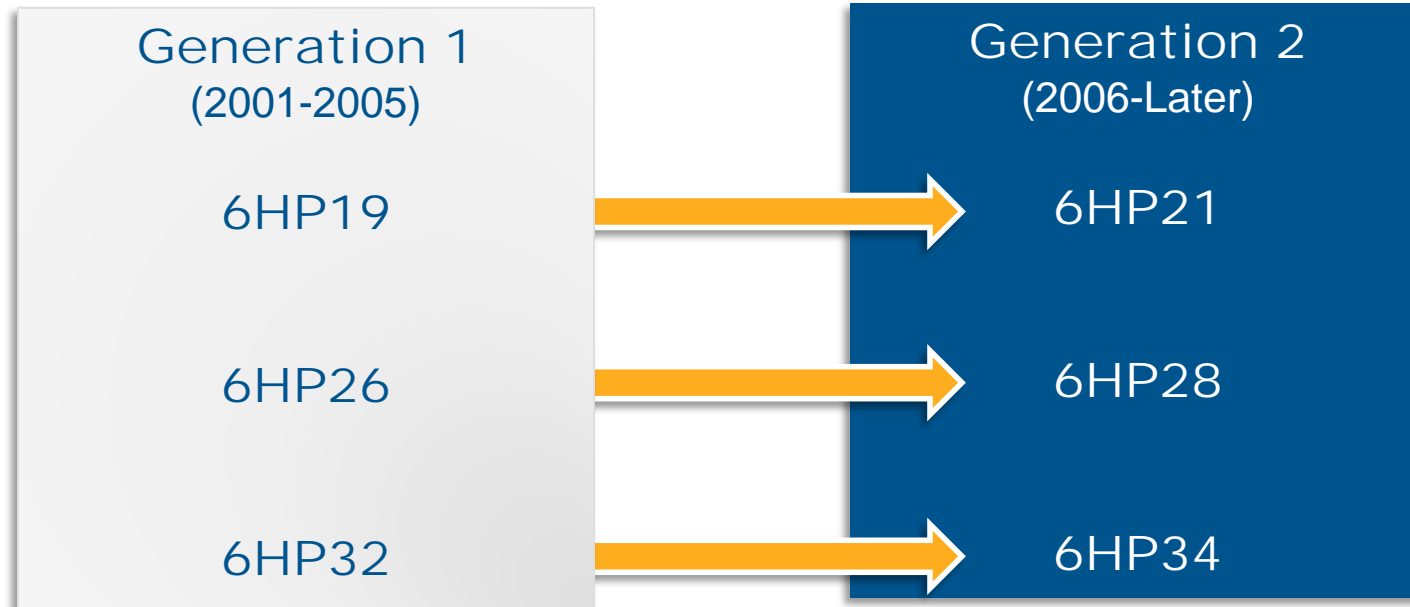

- Generation 2 was developed to improve shift times.
- The improved shift time makes the ZF automatic more competitive with DSG design transmissions.

# ZF6 Generation 2

"E" Shift

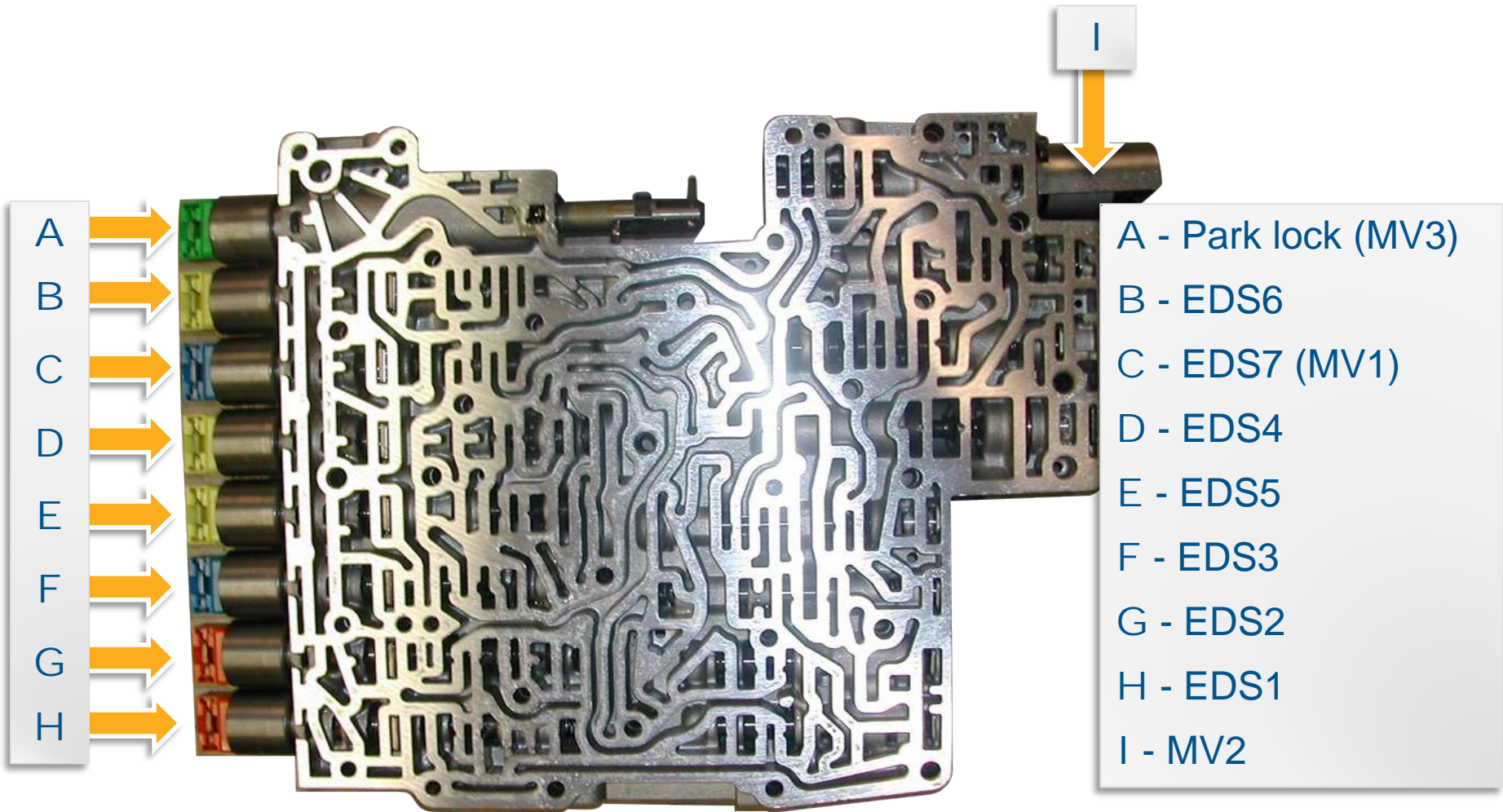

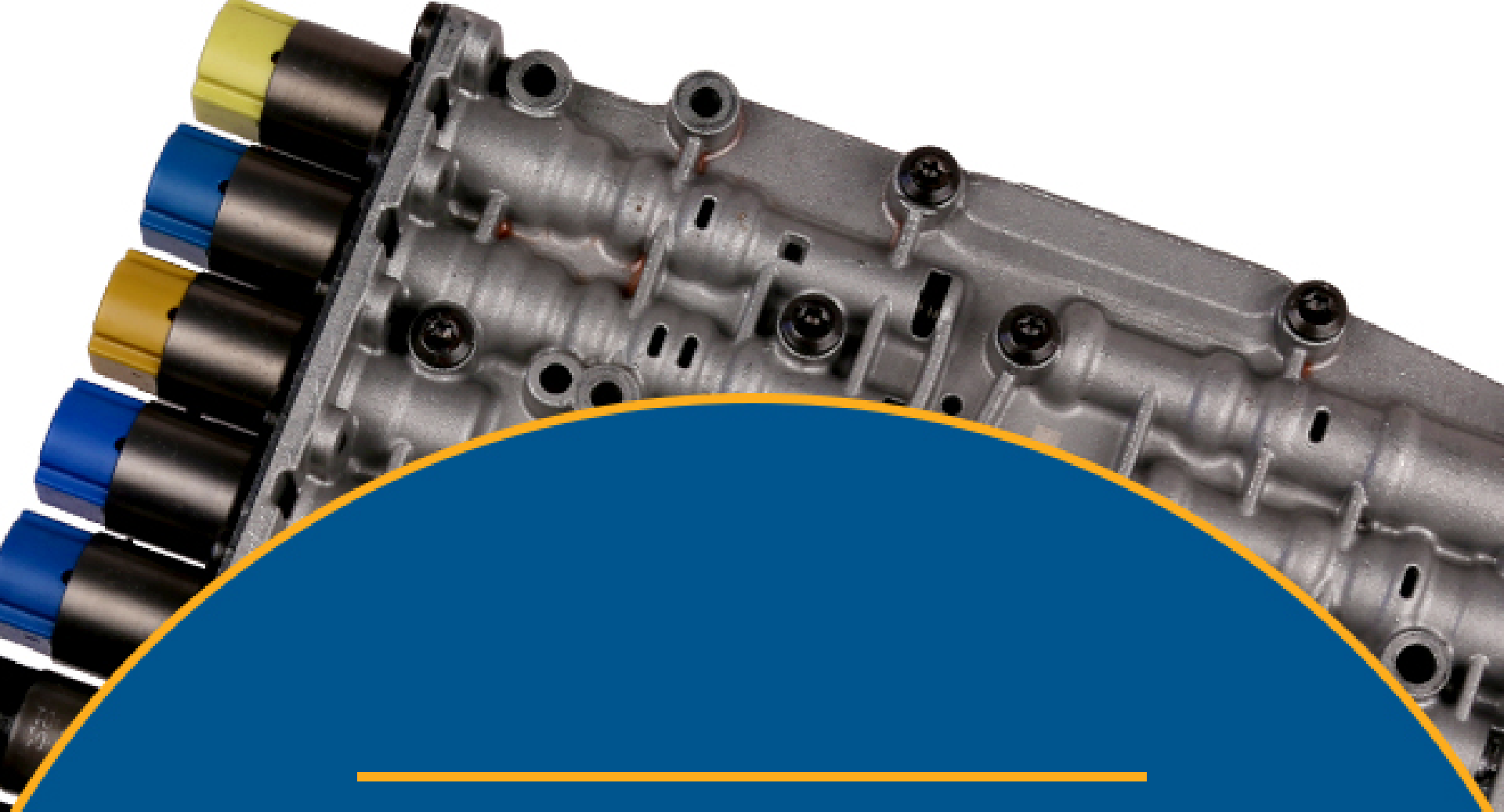

---

# ZF6 Solenoids

---

# ZF6 Solenoids

## Normally Vented vs. Normally Applied

- Two designs:
  - **Normally vented** - The solenoid exhaust is open when the solenoid is in the OFF position. When the duty cycle increases, pressure controlling the valve is allowed to operate the valve.
  - **Normally applied** - The solenoid exhaust is closed when the solenoid is in the OFF position. When the duty cycle increases, pressure controlling the valve is allowed to exhaust.
- Normally vented:
  - **Gen. 1:** EDS1, EDS3, EDS6
  - **Gen. 2:** EDS1, EDS2, EDS4, EDS5, EDS6
- Normally applied:
  - **Gen. 1:** EDS2, EDS4, EDS5
  - **Gen. 2:** EDS3, EDS7

# ZF6 Solenoids

- PWM controlled - most solenoids
- Normal current flow:
  - **High duty cycle command** - typically 700-850 mA
  - **Low duty cycle command** - typically 50-100 mA
  - The TCM varies the commanded solenoid amperage to vary the output pressure available from the solenoid.
- Typical PWM solenoid resistance at 20c is 5-6 ohms.
- Varies by Manufacturer:
  - **VFS#**
  - **EDS#**
  - **N###**

# Solenoid Function

Gen. 1

Solenoid Name	Solenoid Style	Resistance at 68f (20c)	Connector Color	Function
MV1	On/Off	10-10.5 Ohms	Black	Controls a valve to allow EDS4 control of E Clutch
MV2	On/Off	10-10.5 Ohms	Black	Park
MV3	On/Off	24-26 Ohms	Green	Park
EDS1	NV (PWM)	5 Ohms	Yellow	A Clutch
EDS2	NA (PWM)	5 Ohms	Blue	B Clutch
EDS3	NV (PWM)	5 Ohms	Yellow	C Clutch
EDS4	NA (PWM)	5 Ohms	Blue	D/E Clutch
EDS5	NA (PWM)	5 Ohms	Blue	Pressure Control
EDS6	NV (PWM)	5 Ohms	Yellow	TCC

# Solenoid Function

Gen. 2

Solenoid Name	Solenoid Style	Resistance at 68f (20c)	Connector Color	Function
MV1	On/Off	10-10.5 Ohms	Black	Controls a valve to allow EDS4 control of E Clutch
MV2	On/Off	10-10.5 Ohms	Black	Park
MV3	On/Off	24-26 Ohms	Green	Park
EDS1	NV (PWM)	5 Ohms	Orange	A Clutch
EDS2	NV (PWM)	5 Ohms	Orange	TCC
EDS3	NA (PWM)	5 Ohms	Blue	B Clutch
EDS4	NV (PWM)	5 Ohms	Yellow	E Clutch
EDS5	NV (PWM)	5 Ohms	Yellow	C Clutch
EDS6	NV (PWM)	5 Ohms	Yellow	D Clutch
EDS7	NA (PWM)	5 Ohms	Blue	PCS

# Typical Solenoid Configuration

6HP19/26/32 (Gen. 1)

M shift: 1 black; 3 blue; 3 yellow

M shift: 1 black; 1 blue; 5 yellow

E shift: 2 black; 1 green; 3 blue; 3 yellow; MV

6HP21/28 (Gen. 2)

E shift: 2 orange; 1 green; 2 blue; 3 yellow; MV

M shift: 2 orange; 2 blue; 3 yellow



# Various Solenoids

Gen. 1 – 6HP19, 6HP26, 6HP32

<b>Gear</b>	<b>SSA</b> VFS1, EDS1, N215 1-2-3-4 Solenoid Normally Vented	<b>SSB</b> VFS2, EDS2, N216 3-5-R Solenoid Normally Applied	<b>SSC</b> VFS3, EDS3, N217 2-6 Solenoid Normally Vented	<b>SSD</b> VFS4, EDS4, N218 1-4-5-6 Solenoid Normally Applied
<b>Park</b>				On (850 mA)
<b>Reverse</b>		On (850 mA)		On (850 mA)
<b>Neutral</b>				On (850 mA)
<b>1<sup>st</sup></b>	On (850 mA)			On (850 mA)
<b>2<sup>nd</sup></b>	On (850 mA)		On (850 mA)	
<b>3<sup>rd</sup></b>	On (850 mA)	On (850 mA)		
<b>4<sup>th</sup></b>	On (850 mA)			On (850 mA)
<b>5<sup>th</sup></b>				On (850 mA)
<b>6<sup>th</sup></b>		On (850 mA)	On (850 mA)	On (850 mA)

# Various Solenoids

Gen. 1 – 6HP19, 6HP26, 6HP32

<b>Gear</b>	<b>Pressure Control</b> VFS5, EDS5, N233 Normally Applied	<b>TCC</b> VFS6, EDS6, N371 Normally Vented	<b>SSE</b> N88, MV1	<b>MV2</b>	<b>MV3</b>
<b>Park</b>	Duty Cycle Varies				
<b>Reverse</b>	Duty Cycle Varies		On (E Shift)	On (E Shift)	On (E Shift)
<b>Neutral</b>	Duty Cycle Varies		On (E Shift)	On (E Shift)	On (E Shift)
<b>1<sup>st</sup></b>	Duty Cycle Varies	Duty Cycle Varies: 100 - 700 mA	On (E Shift)	On (E Shift)	On (E Shift)
<b>2<sup>nd</sup></b>	Duty Cycle Varies	Duty Cycle Varies: 100 - 700 mA	On (E Shift)	On (E Shift)	On (E Shift)
<b>3<sup>rd</sup></b>	Duty Cycle Varies	Duty Cycle Varies: 100 - 700 mA			On (E Shift)
<b>4<sup>th</sup></b>	Duty Cycle Varies	Duty Cycle Varies: 100 - 700 mA	On		On (E Shift)
<b>5<sup>th</sup></b>	Duty Cycle Varies	Duty Cycle Varies: 100 - 700 mA	On		On (E Shift)
<b>6<sup>th</sup></b>	Duty Cycle Varies	Duty Cycle Varies: 100 - 700 mA	On		On (E Shift)

# Various Solenoids

Gen. 2 – 6HP21, 6HP28, 6HP34

<b>Gear</b>	<b>SSA</b> VFS1, EDS1, N215 1-2-3-4 Solenoid	<b>SSB</b> VFS2, EDS2, N216 1-2-4-6 Solenoid	<b>SSC</b> VFS3, EDS5, N217 2-6 Solenoid	<b>SSD</b> VFS4, EDS6, N218 Rev-1 Solenoid
<b>Park</b>				
<b>Reverse</b>				On (850 mA)
<b>Neutral</b>				
<b>1<sup>st</sup></b>	On (850 mA)	On (850 mA)		On (850 mA)
<b>2<sup>nd</sup></b>	On (850 mA)	On (850 mA)	On (850 mA)	
<b>3<sup>rd</sup></b>	On (850 mA)			
<b>4<sup>th</sup></b>	On (850 mA)	On (850 mA)		
<b>5<sup>th</sup></b>				
<b>6<sup>th</sup></b>		On (850 mA)	On (850 mA)	

# Various Solenoids

Gen. 2 – 6HP21, 6HP28, 6HP34

<b>Gear</b>	<b>SSE</b> N288, EDS4 4-5-6 Solenoid	<b>TCC</b> EDS2, N371	<b>Pressure Control</b> EDS7, N233	<b>SSE</b> N88, MV1	<b>MV2</b>	<b>MV3</b>
<b>Park</b>			Duty Cycle Varies			
<b>Reverse</b>			Duty Cycle Varies	On (E Shift)	On (E Shift)	On (E Shift)
<b>Neutral</b>			Duty Cycle Varies	On (E Shift)	On (E Shift)	On (E Shift)
<b>1<sup>st</sup></b>		Duty Cycle Varies: 100 - 700 mA	Duty Cycle Varies	On (E Shift)	On (E Shift)	On (E Shift)
<b>2<sup>nd</sup></b>		Duty Cycle Varies: 100 - 700 mA	Duty Cycle Varies	On (E Shift)	On (E Shift)	On (E Shift)
<b>3<sup>rd</sup></b>		Duty Cycle Varies: 100 - 700 mA	Duty Cycle Varies			On (E Shift)
<b>4<sup>th</sup></b>	On (850 mA)	Duty Cycle Varies: 100 - 700 mA	Duty Cycle Varies	On		On (E Shift)
<b>5<sup>th</sup></b>	On (850 mA)	Duty Cycle Varies: 100 - 700 mA	Duty Cycle Varies	On		On (E Shift)
<b>6<sup>th</sup></b>	On (850 mA)	Duty Cycle Varies: 100 - 700 mA	Duty Cycle Varies	On		On (E Shift)

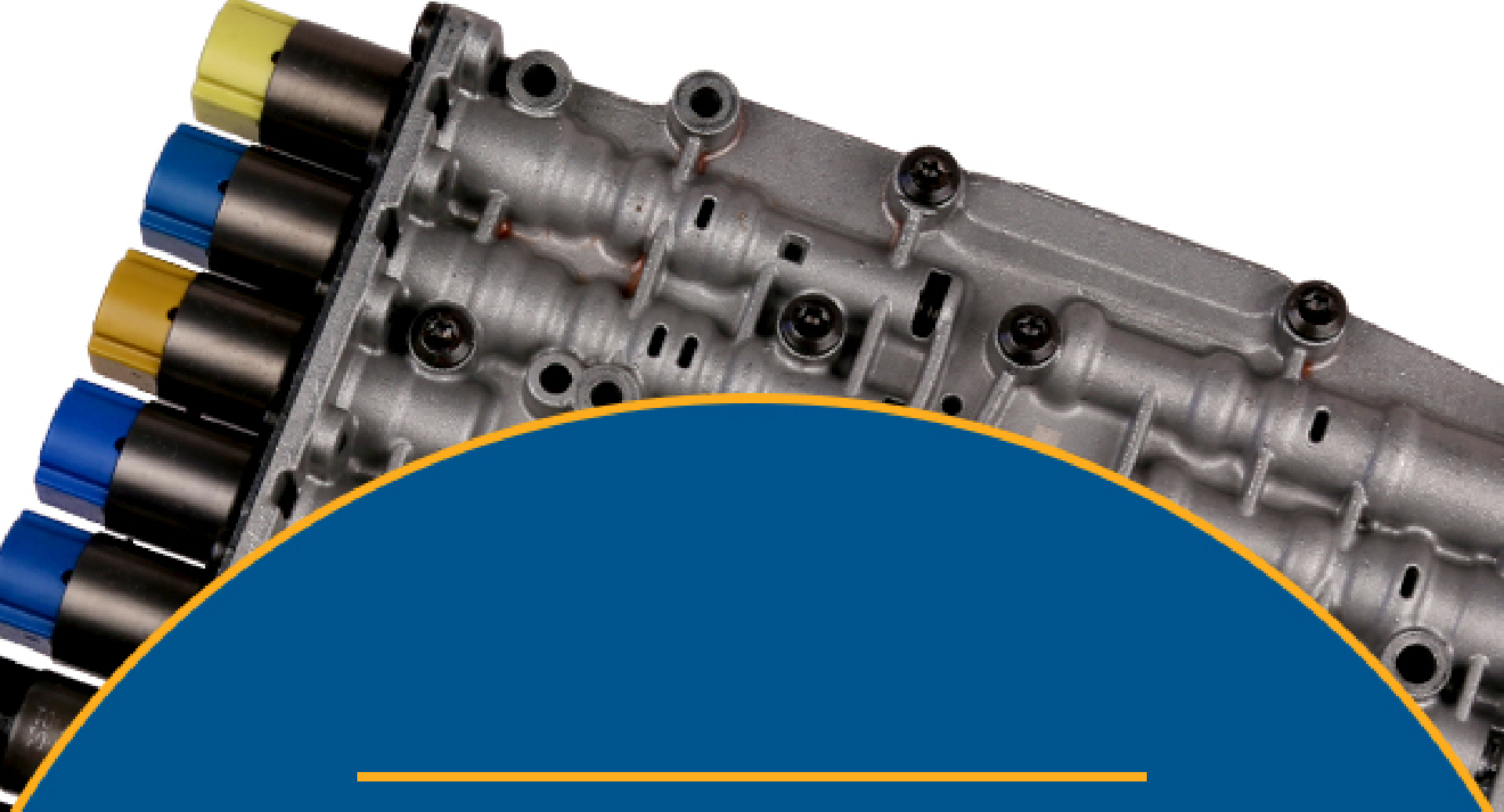

---

# ZF6 Identification

---

# ZF6 Identification

Gen. 1 - 6HP19, 6HP26, 6HP32: M-Type

MV1

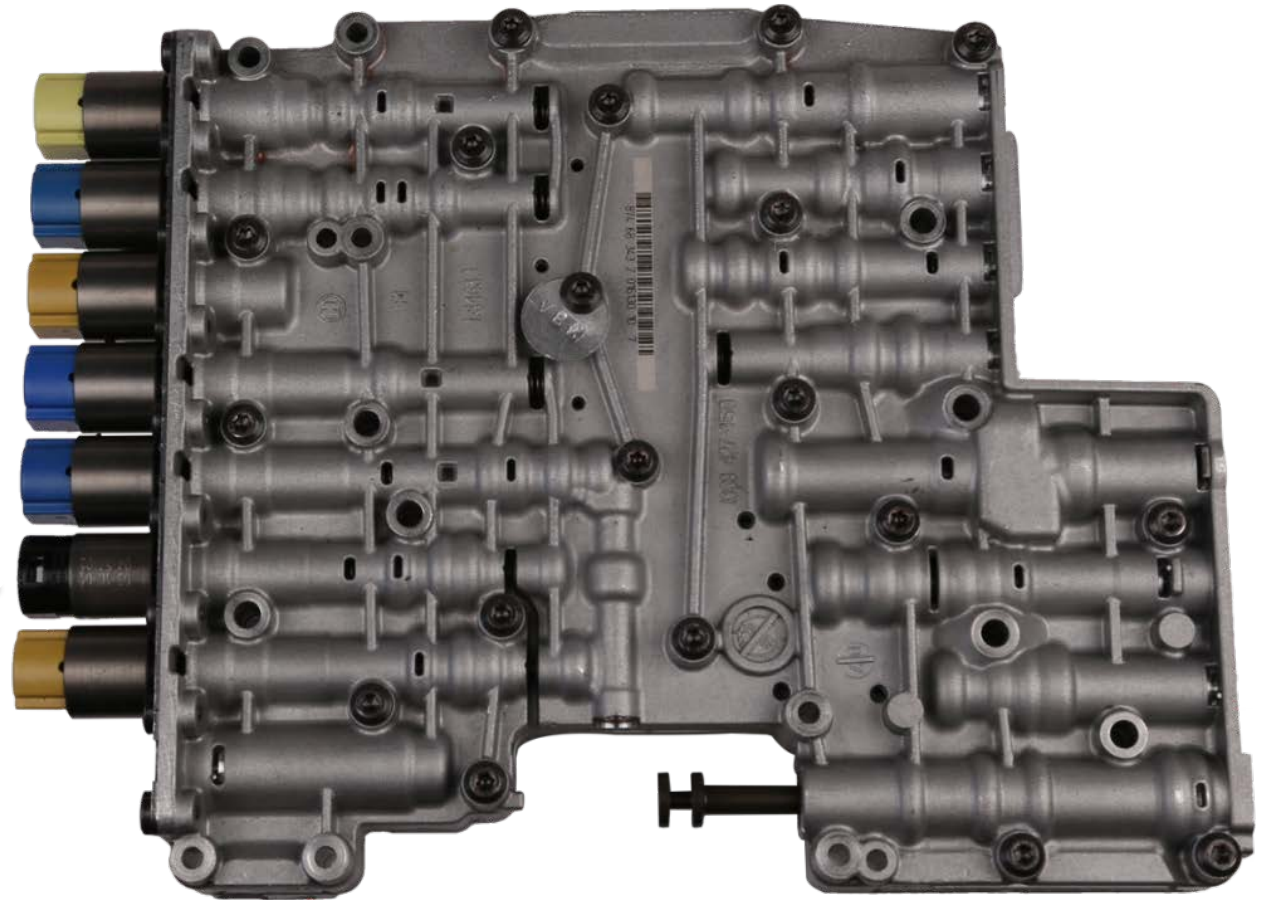

# ZF6 Identification

Gen. 2 - 6HP21, 6HP28, 6HP34

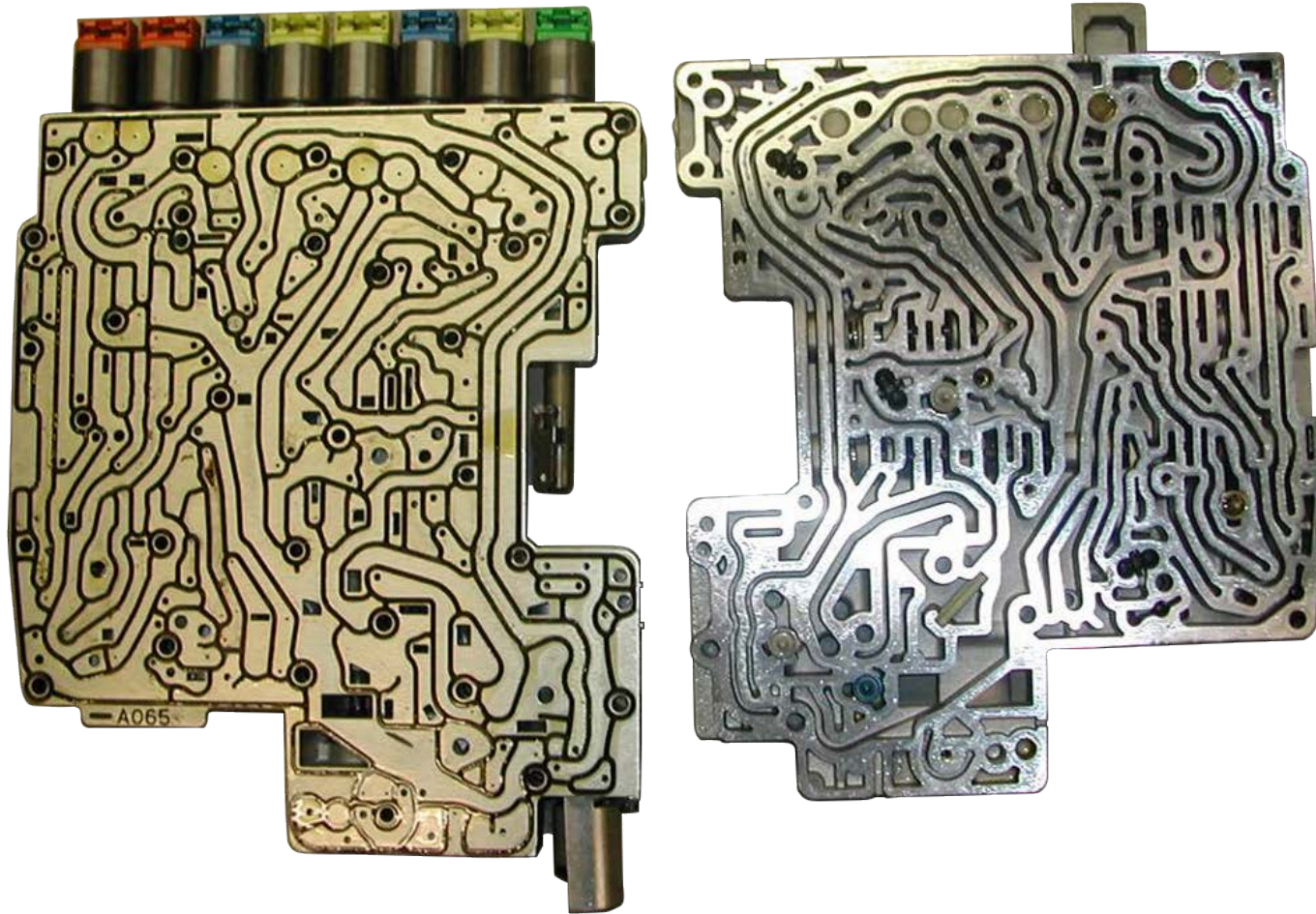

# Valve Function ZF Terms

ZF Term	Common Term	Explanation
Selector Spool	Manual Valve	Acts as the “Manual” valve.
Shift Selector Valve 1	Shift Valve 1 SHV-1	Known as the emergency run on valve. This valve maintains actual gear selected if you lose power (B+) to the transmission.
Shift Selector Valve 2	Shift Valve 2 SHV-2	Controlled by solenoid 2, provides pressure to relevant clutches.
Shift Selector Valve 3	Shift Valve 3 SHV-3	Controls pressure to the D Clutch on Gen. 2 applications.
Retaining Valve	Latching Valve Position Valve Boost Valve A, B, C, D Clutches/Brake	Control/actuate the clutch valves. These valves “latch” the clutch valve operation during the shift so clutch apply PSI raises to line pressure. Both the retaining valves and the clutch valves are controlled by the solenoids.
Clutch Valve	Clutch Regulator Valve A, B, C, D, E	Act as <b>variable</b> pressure regulator valves which are used to control clutch pressure.
Pressure Reducing Valve	Solenoid Regulator Valve	Lowers pressure to 5 bar to feed the solenoids.
Lube Valve	Lubrication Control Valve	Controls lube PSI.
Converter Pressure Valve	Converter Release Regulator	Controls converter pressure when TCC is OFF.
System Pressure Valve	Pressure Regulator	Controls line pressure.
Converter Lockup Valve	Bypass Clutch Control Valve	Controlled by EDS6. Controls the TCC.
Position Valve	E-shift Only	Replaces the selector spool.



# ZF6 Identification

## Gen. 1 vs. Gen. 2 – Valve Body Differences

1st Generation Case Side  
Includes 19, 26 & 32



### 1. IDENTIFY!

2nd Generation Case Side  
Includes 21, 28 & 34

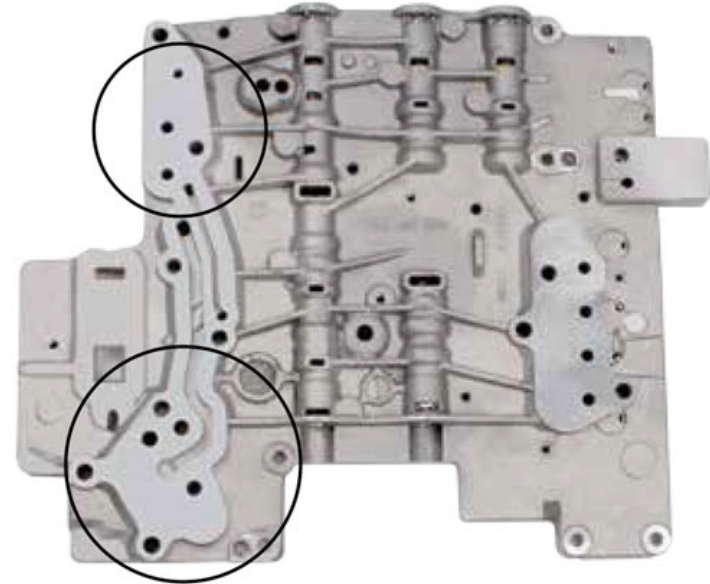

# ZF6 Identification

## Gen. 1 vs. Gen. 2 – Valve Body Differences

### 2. VERIFY!

Different Sized Pressure Regulator Valves and Sleeves



Pressure Regulator Valves and Sleeves Cannot Be Interchanged



Verify OE dimensions indicated in order to select correct Sonnax replacement kits.

Some BMW 6 & 7 series with six accumulators have a different sized pressure regulator valve. This is most commonly seen on the A053/B053 separator plate applications.

# Valve Body Identification

E-Shift, Lower – Solenoid Side



# Valve Body Identification

M-Shift, Lower – Solenoid Side



Gen. 1



Gen. 2

# Valve Body Identification

E-Shift, Lower – PR Valve Side



Gen. 1



Gen. 2

# Valve Body Identification

M-Shift, Lower – PR Valve Side



Gen. 1



Gen. 2

# ZF Valve Latching Animation

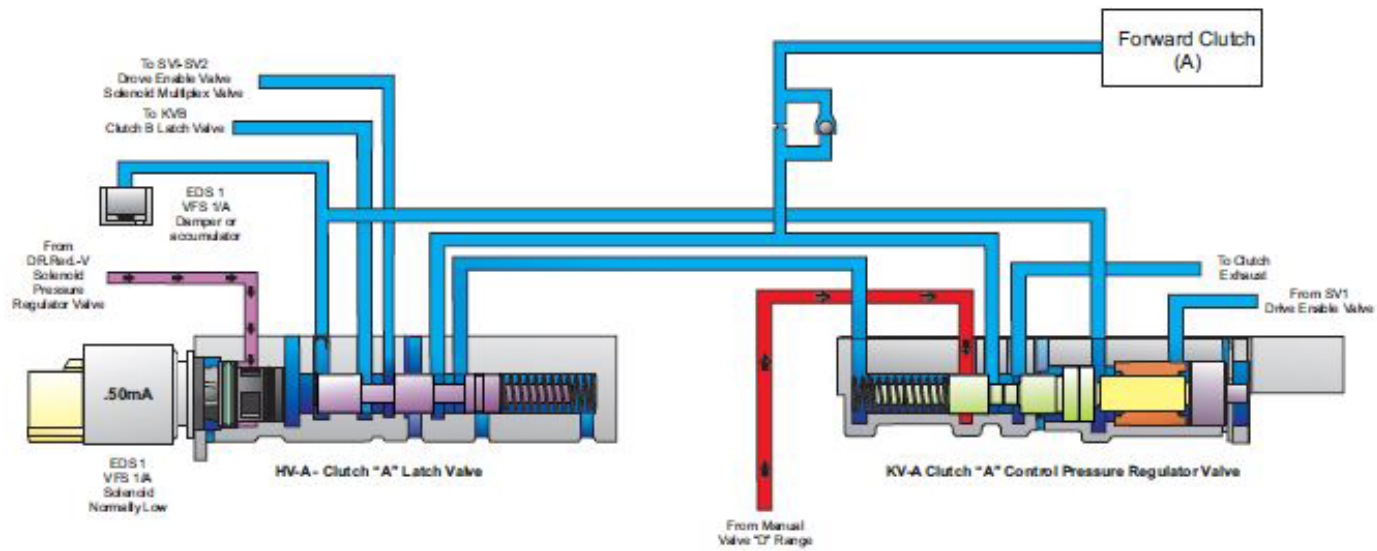

Figure 1

# ZF Valve Latching Animation

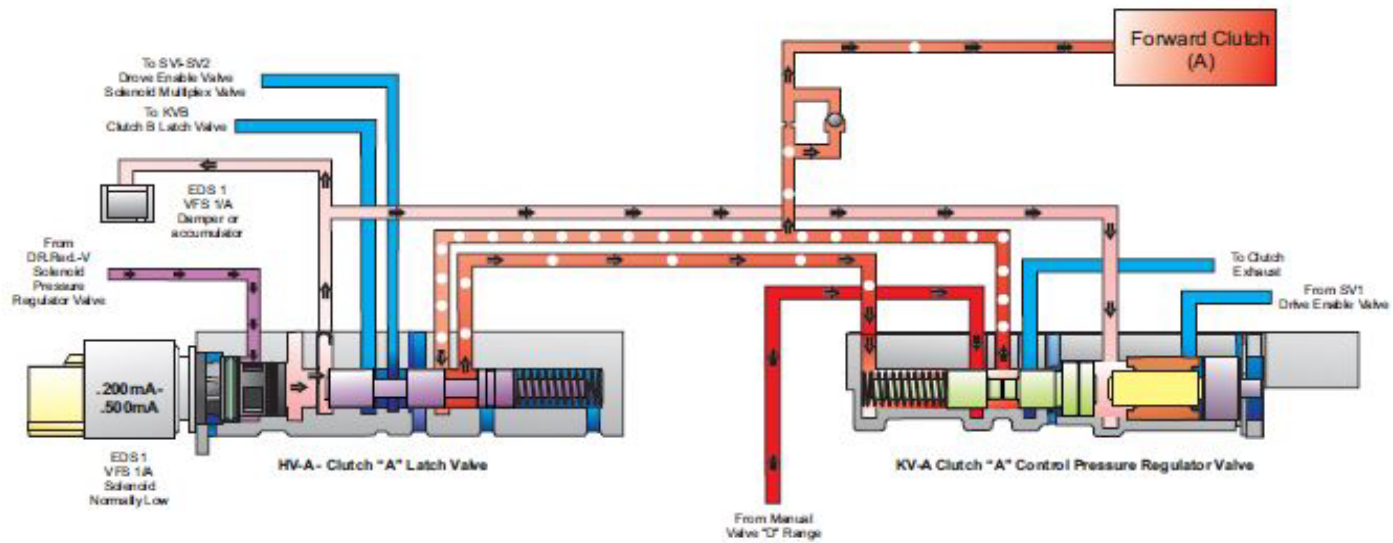

Figure 2



# ZF Valve Latching Animation

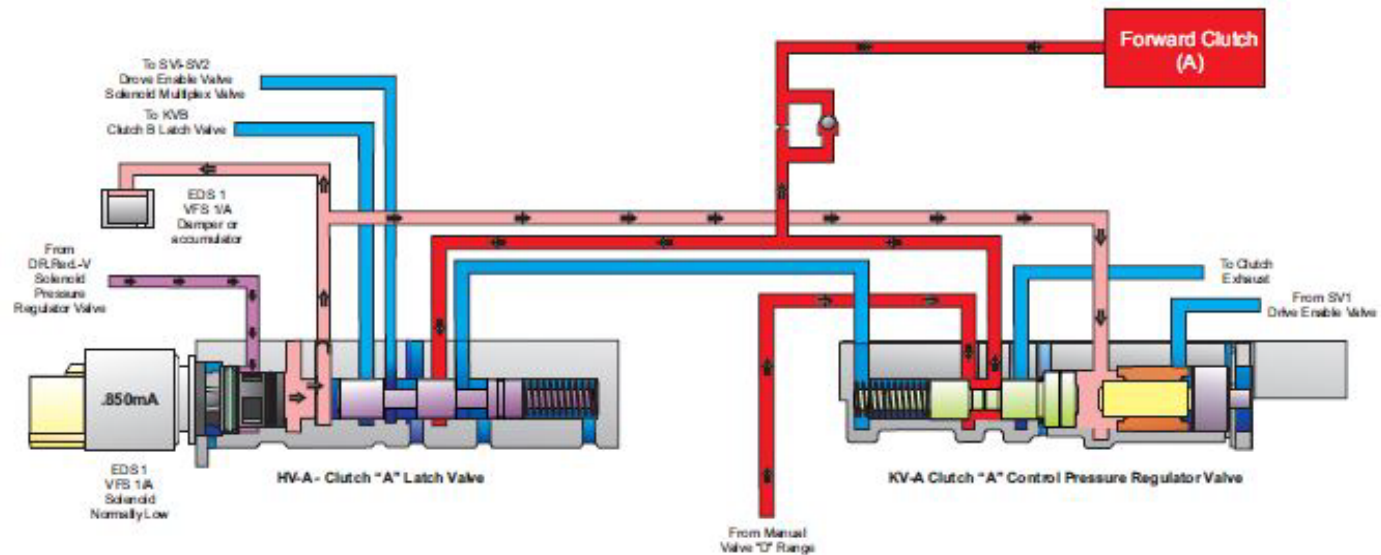
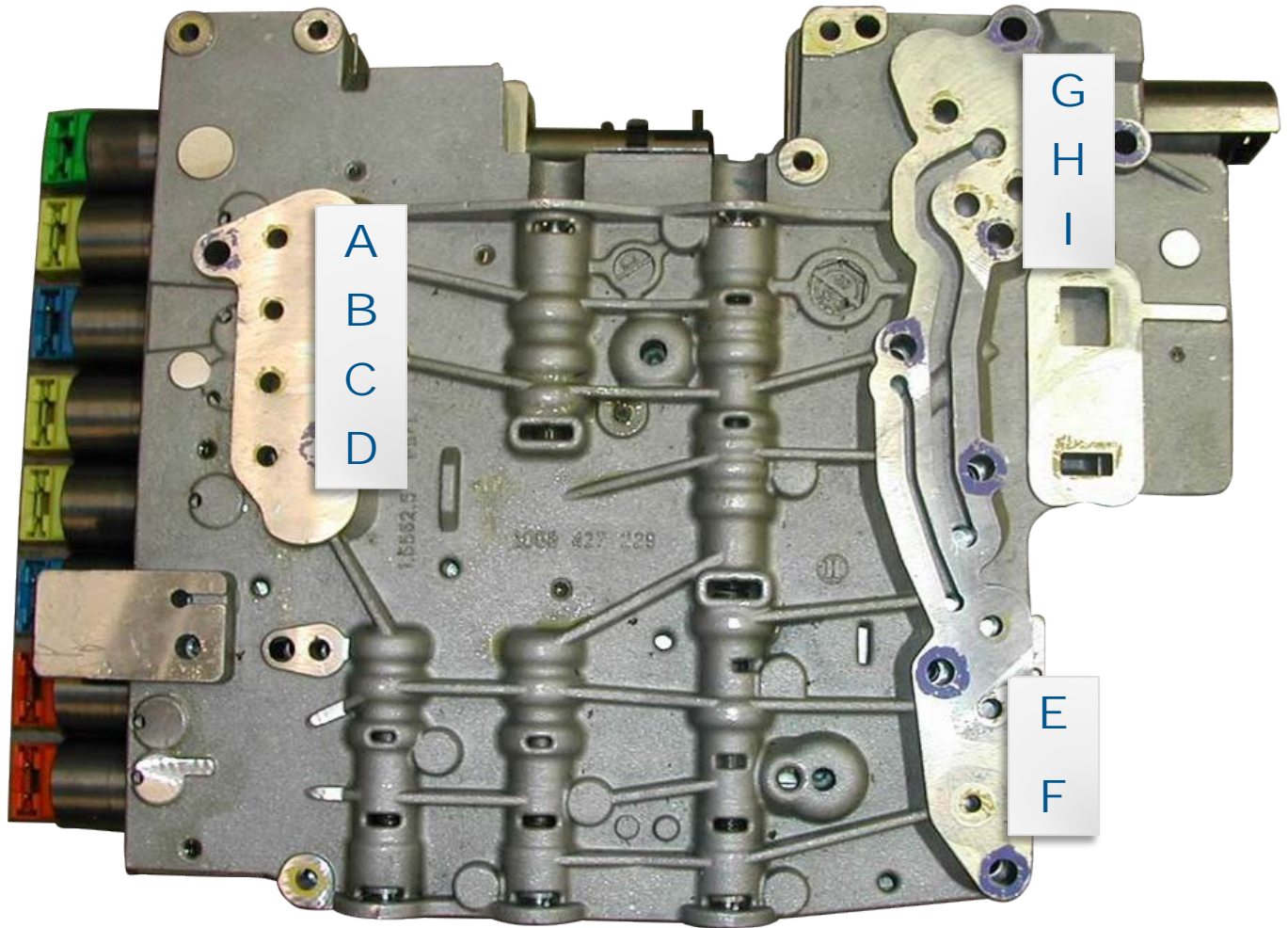

Figure 3

# Valve Body Fluid Flow



## Clutch Feed:

A = C clutch

B = D clutch

C = D clutch

D = B clutch

E = E clutch

F = A clutch

G = To cooler

H = TCC apply

I = TCC release

# Valve Body Wear Issues

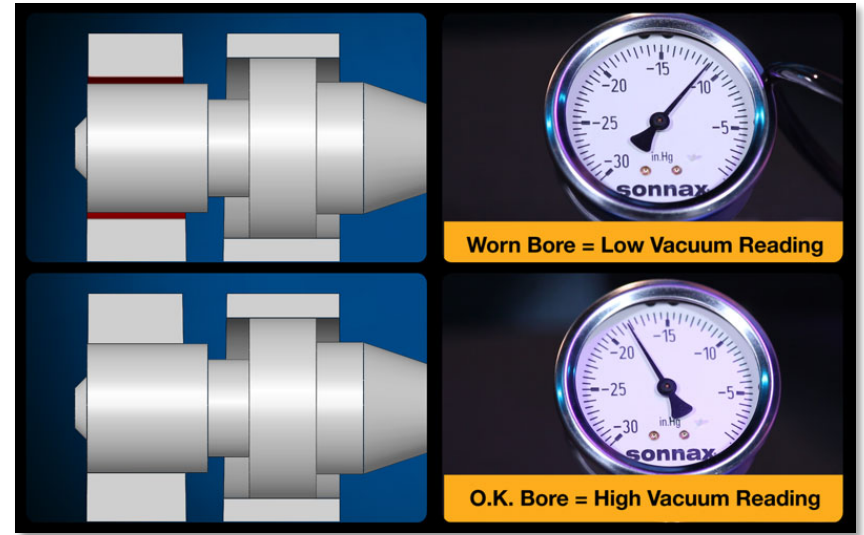
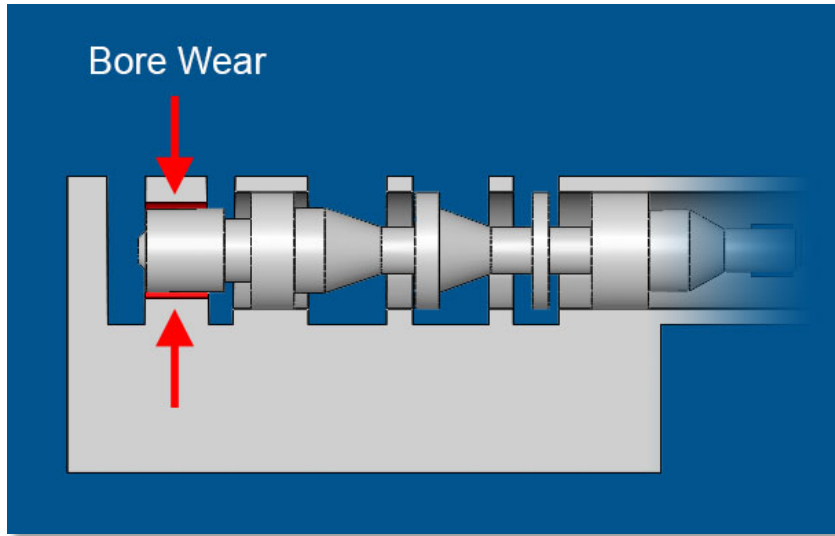

- Valve body wear is common in many of the ZF 6-speed applications.
- Vacuum testing will allow you to identify worn areas.

# Remanufactured Valve Bodies

Available from Sonnax

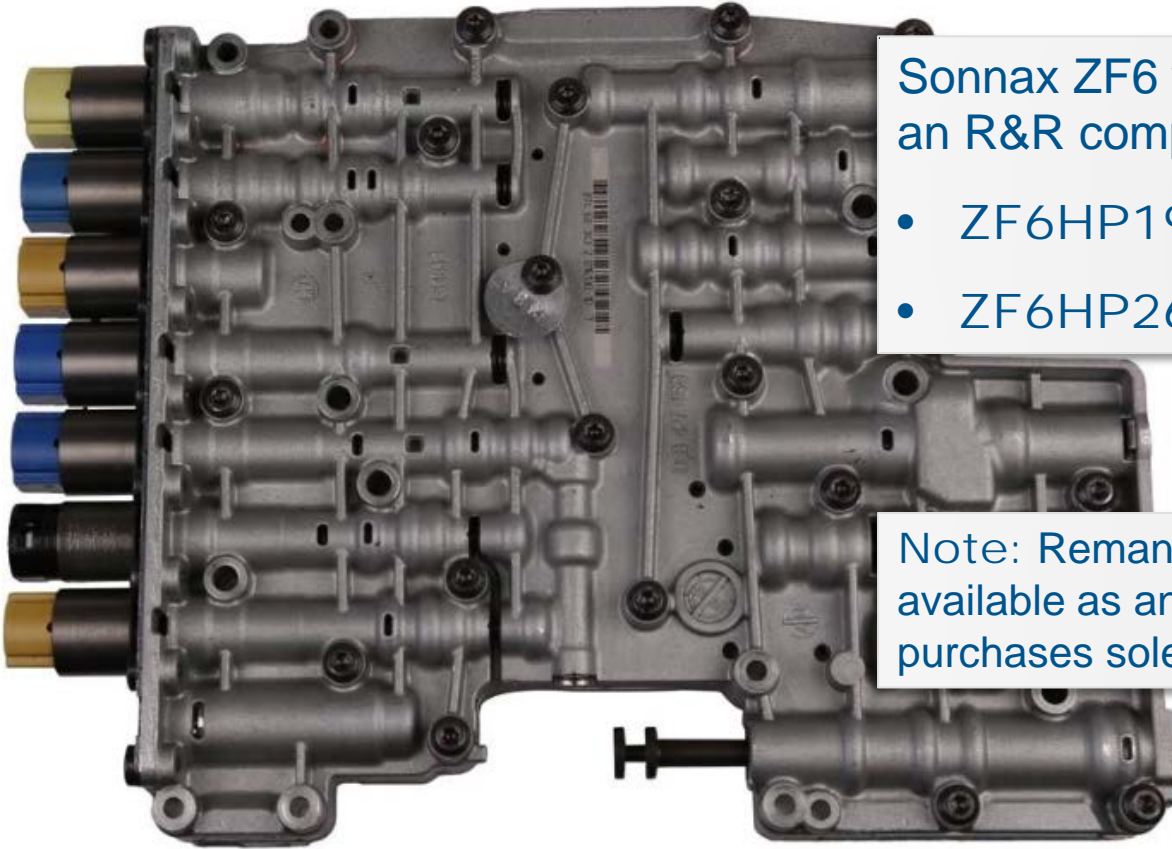

Sonnax ZF6 valve bodies are available as an R&R component due to build variations:

- ZF6HP19 - Part No. BMW619
- ZF6HP26 - Part No. BMW626

Note: Remanufactured solenoids are also available as an R&R component. Sonnax purchases solenoid cores.

# Valve Body Wear Solutions

Part No. ZF6-6R60-ZIP (Gen. 1)



Pressure Regulator Sleeve



Clutch A Control Boost Valve & Sleeve Kit



O-Ringed Internal End Plug Kit  
(4 plugs, 11 O-rings)



Valve Body Accumulator  
Piston & Spring Kit  
(6 of each)



Replacement Solenoid O-Rings  
(31 various pieces)



O-Ringed End Plug Kit  
(12 plugs, 18 O-rings)



Testing Parts



## ZIP KIT®

- No reaming required.
- Installs quickly with no special tools required.
- Uniquely designed parts address root causes of valve body complaints by sealing critical pressure circuits.
- Detailed technical booklet included with in-depth rebuild and inspection tips for valve body repair.

# Valve Body Wear Solutions

Part No. ZF6-GEN2-ZIP (Gen. 2)



Pressure Regulator Sleeve



O-Ringed Internal End Plug Kit  
(7 plugs, 20 O-rings)



Valve Body Accumulator  
Piston & Spring Kit  
(7 of each)



O-Ringed End Plug Kit  
(8 plugs, 13 O-rings)

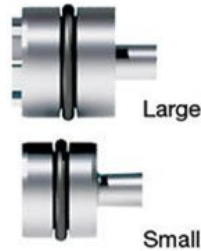

Clutch A & E Control Boost  
Valve & Sleeve Kit  
(2 of each)



Replacement Solenoid O-Rings  
(31 various pieces)



Testing Parts



## ZIP KIT<sup>®</sup>

- No reaming required.
- Installs quickly with no special tools required.
- Uniquely designed parts address root causes of valve body complaints by sealing critical pressure circuits.
- Detailed technical booklet included with in-depth rebuild and inspection tips for valve body repair.



---

# ZF6 Parts

---

# ZF6 Accumulators

Gen. 1 & Gen. 2

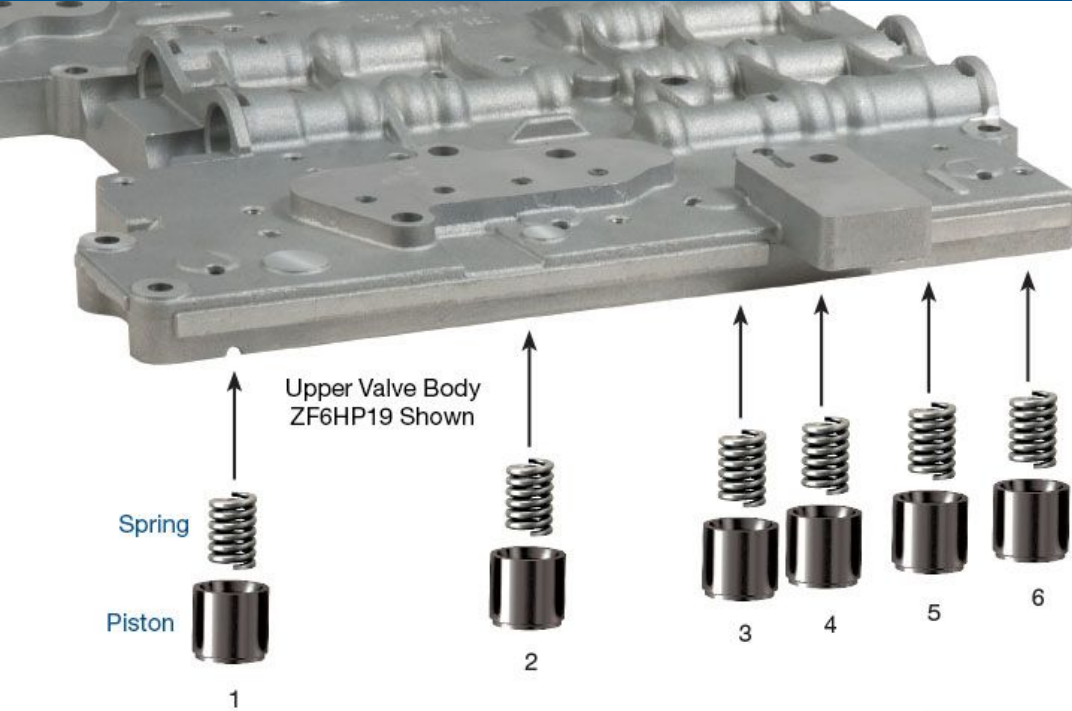

## Symptoms:

- Erratic EDS solenoid control and/or EDS codes
- Firm shifts
- Harsh engagement

## 95740-15K Accumulator Piston Kit:

- Hard-coat anodized aluminum to resist wear
- New matching springs reproduce OE function
- Direct replacement, no special tools required



# Solenoid Regulators

Gen. 1



## 95740-17K Oversized Solenoid Pressure Regulator Valve Kit:

- Hard-coat anodized aluminum valve resists wear
- New matching spring reproduces OE function with the oversized valve

### Symptoms:

- Delayed Forward
- Delayed Reverse
- Flare shifts
- Gear ratio codes
- Harsh downshifts
- Harsh upshifts
- Neutral shifts
- Solenoid codes
- Wrong gear starts

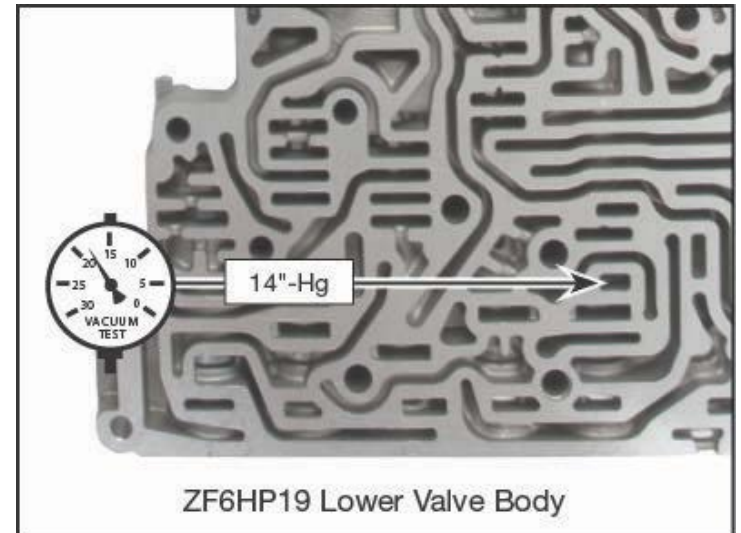

# Solenoid Regulators

Gen. 2



## Symptoms:

- Delayed engagement
- Flare shifts
- Gear ratio & solenoid codes
- Harsh downshifts
- Harsh upshifts
- High line pressure
- Neutral shifts
- Wrong gear starts

## 95740-64K Oversized Solenoid Pressure Regulator Valve Kit:

- Kit fits either M-shift or E-shift valve bodies
- Valve is hard-coat anodized to reduce wear
- Matching spring reproduces OE function with the oversized valve

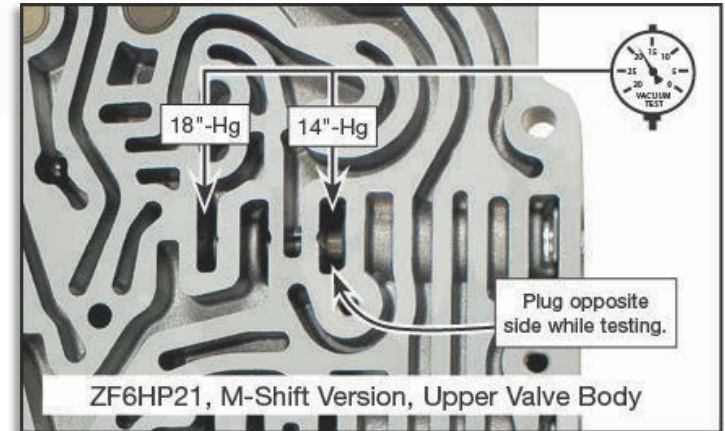

# Shift Valve 3

Gen. 2



Symptoms:

- D1 Brake burned
- Harsh Reverse
- Reverse slip

95740-74K

## Oversized Shift Valve 3 Kit:

- Valve is hard-coat anodized to reduce wear
- Spring reproduces OE function with the oversized valve
- O-Ringed end plug reduces or eliminates end plug leakage

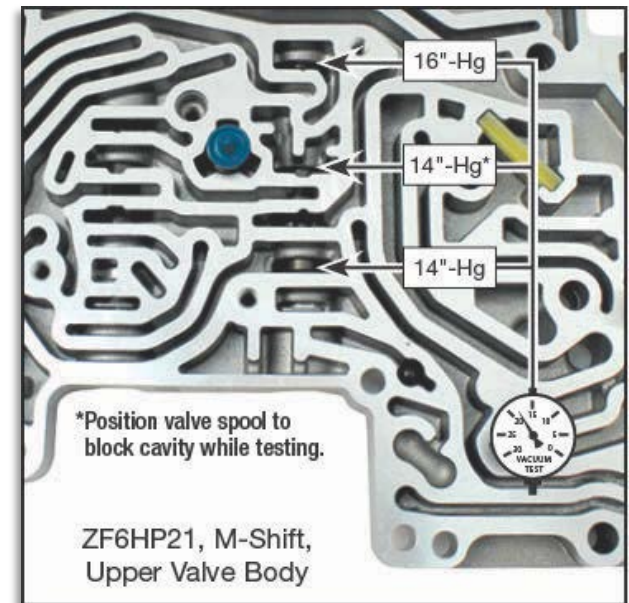

# Pressure Regulator

Gen. 1

Cannot be used in units that have a 053 separator plate.



ZF6HP19, Lower Valve Body

## 95740-01K Oversized Pressure Regulator Valve Kit:

- Hard-coat anodized aluminum valve resists wear
- Alloy aluminum sleeve is significantly more wear-resistant than the OE sleeve
- Salvages valve body castings



## Symptoms:

- Delayed Reverse
- Erratic line pressure
- No Reverse
- Poor shift quality
- Slips in Forward & Reverse

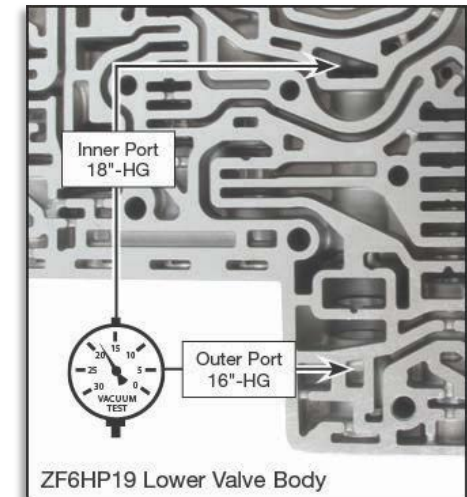

# Pressure Regulator

Gen. 1

Fits units with 053 separator plate only.

ZF6HP26 Lower  
Valve Body



**NOTE:** OE valve & sleeve  
MUST match these  
measurements to use.



Symptoms:

- Broken parts due to excessive line pressure
- Erratic line pressure
- Harsh shifts
- High line pressure
- Restricted converter/lube flow
- Soft shifts

95740-78K

Oversized Pressure Regulator Valve Kit:

- Hard-coat anodized aluminum valve combats premature wear
- Sleeve manufactured from highly wear-resistant aluminum

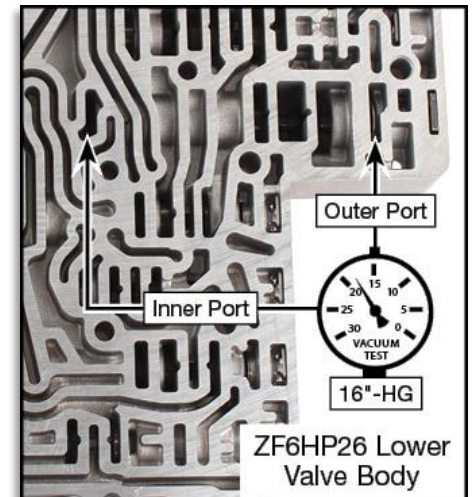

ZF6HP26 Lower  
Valve Body

# Pressure Regulator

Gen. 2



ZF6HP21, Lower Valve Body



95740-69K

Oversized Pressure Regulator Valve Kit:

- Valve is hard-coat anodized to resist wear
- Sleeve is made from highly wear-resistant aluminum

Symptoms:

- Burnt converter
- Delayed Reverse
- High line pressure
- Low line pressure
- No Reverse
- Poor shift quality

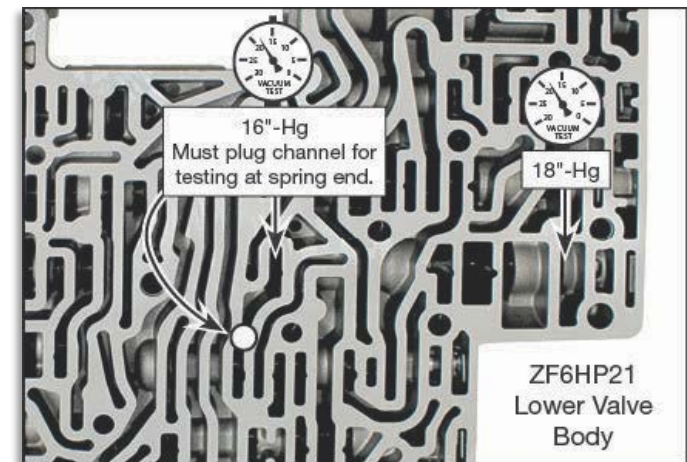

# Pressure Regulator

Gen. 1

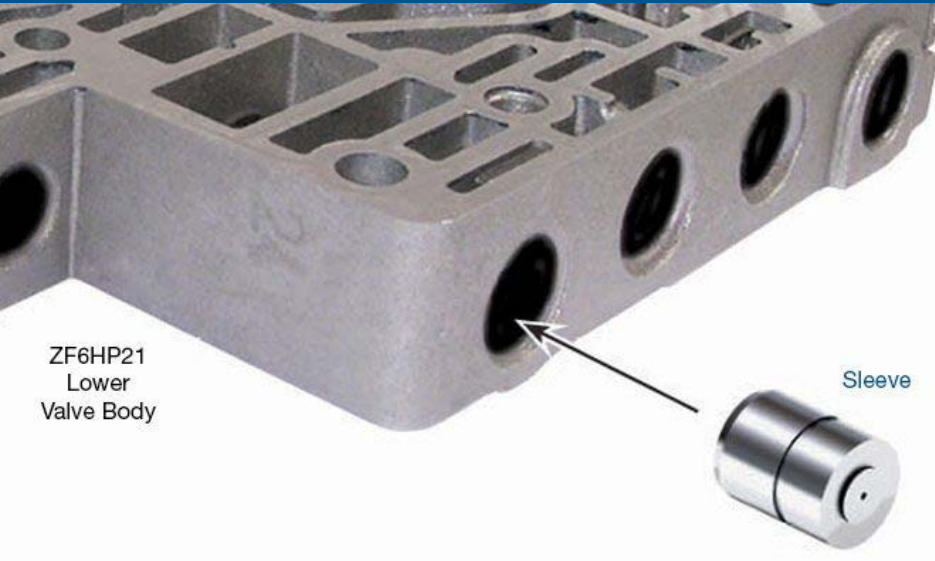

## Symptoms:

- Broken parts due to excessive line pressure
- Erratic line pressure
- High line pressure
- Restricted converter/lube flow

95740-29K

## Pressure Regulator Sleeve:

- Sleeve is highly wear-resistant to increase life
- Direct replacement, no special tools required

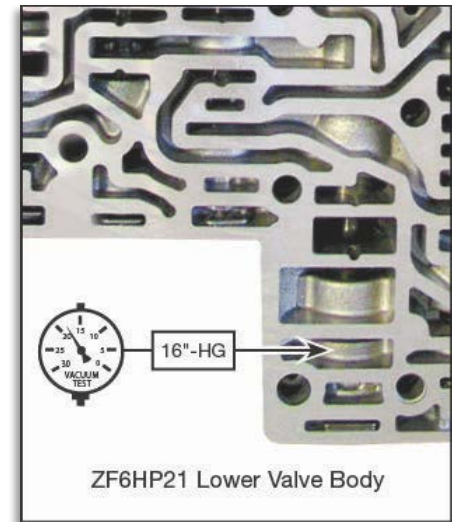

# Position Control

## Gen. 2

This kit fits E-shift versions of Gen. 2 valve bodies only.



### 95740-75K Oversized Position Valve Kit:

- Added annular grooves increase bore and valve spool lubrication
- Valve is hard-coat anodized to reduce wear
- O-Ringed end plug reduces or eliminates end plug leakage

### Symptoms:

- A Clutch burned
- B Clutch burned
- E Clutch burned
- Shift concerns

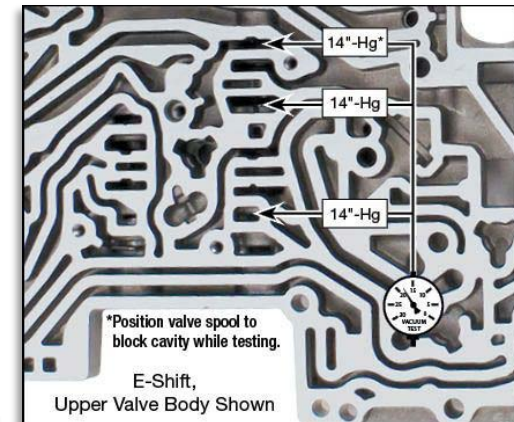



# Lube Control Valve

Gen. 1



ZF6HP19  
Lower  
Valve Body



Valve



End  
Plug

## Symptoms:

- Bump shifts
- Bushing failure
- Flare shifts
- Low converter pressure
- Lube failures
- Overheating
- Planetary failure
- Rough idle in Reverse
- TCC apply & release concerns

95740-11K

## Oversized Lubrication Control Valve Kit:

- Kit fits either M-shift or E-shift valve bodies
- Valve is hard-coat anodized to reduce wear
- Increased valve spool length for additional support at critical sealing area
- O-ringed end plug improves sealing

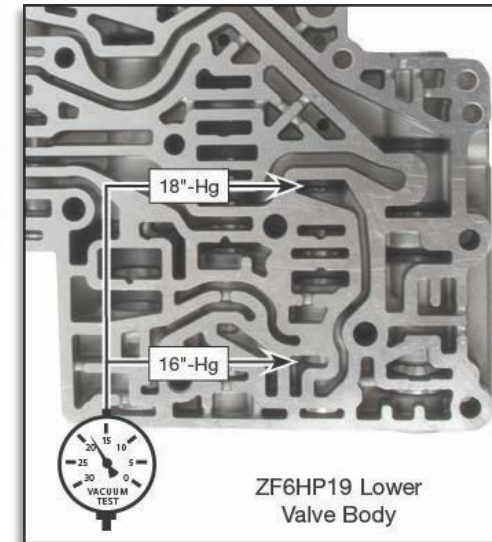

ZF6HP19 Lower  
Valve Body

# Lube Control Valve

Gen. 2



ZF6HP21  
M-Shift Version  
Lower Valve Body

Valve

O-Ringed  
End Plug

## Symptoms:

- Bearing failure
- Overheating
- Planetary failure
- Bushing failure
- Rough idle in Reverse
- Low converter pressure
- TCC codes & concerns
- Lube failures

## 95740-71K Oversized Lubrication Control Valve Kit:

- Kit fits either M-shift or E-shift valve bodies
- Valve is hard-coat anodized to reduce wear
- Increased valve spool length for additional support at critical sealing area
- O-ringed end plug improves sealing

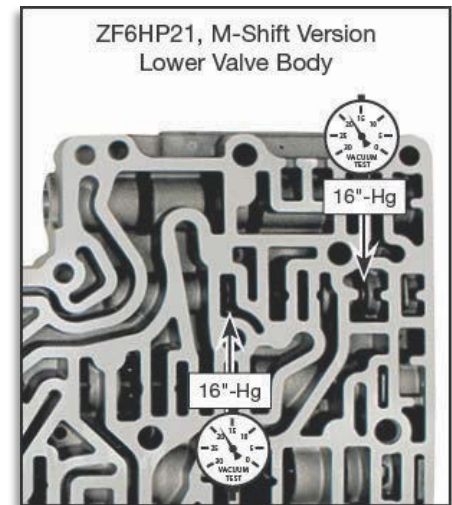

# A and E Clutch Boost Valve

Gen. 1



ZF6HP19  
Lower  
Valve Body

Valve & Sleeve  
Assembly

## Symptoms:

- 5-4 Flare
- 5-4 Neutral
- Delayed Forward
- Harsh Forward
- No 4-5
- VFS 1/A solenoid control code

95740-21K

## Clutch A Control Boost Valve Kit:

- Hard-coat anodized aluminum boost valve resists wear
- Aluminum boost sleeve is highly wear resistant to increase life
- Direct replacement boost assembly works in the OE bore, with the OE clutch control valve, to maintain OE system pressures
- No special tools required

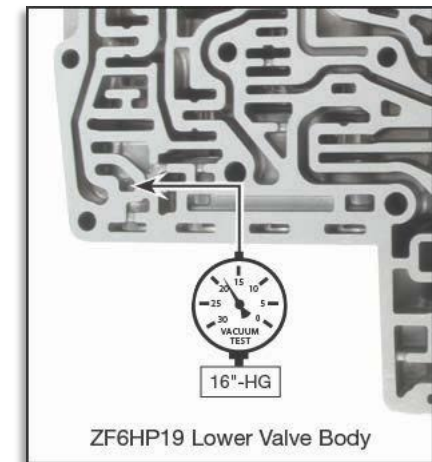

ZF6HP19 Lower Valve Body

# A and E Clutch Boost Valve

Gen. 2



## Symptoms:

- 5-4 Flare
- 5-4 Neutral
- Delayed Forward
- Harsh Forward
- No 4-5
- VFS 1/A solenoid control code

95740-28K

## Clutch A & E Control Boost Valve Kit:

- Hard-coat anodized aluminum valve combats premature wear
- Sleeve is highly wear-resistant to increase service life
- No special tools or reaming required

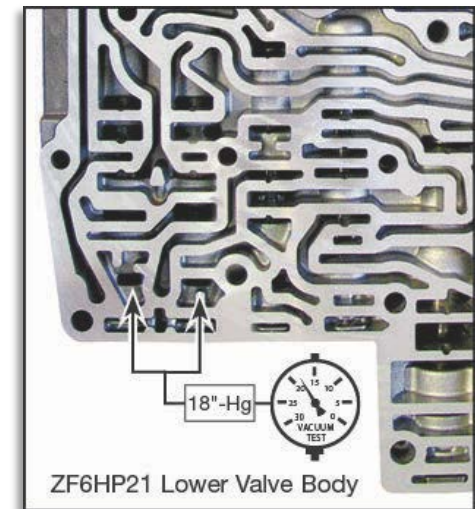

# A and E Clutch Control

Gen. 2 (M-Shift)

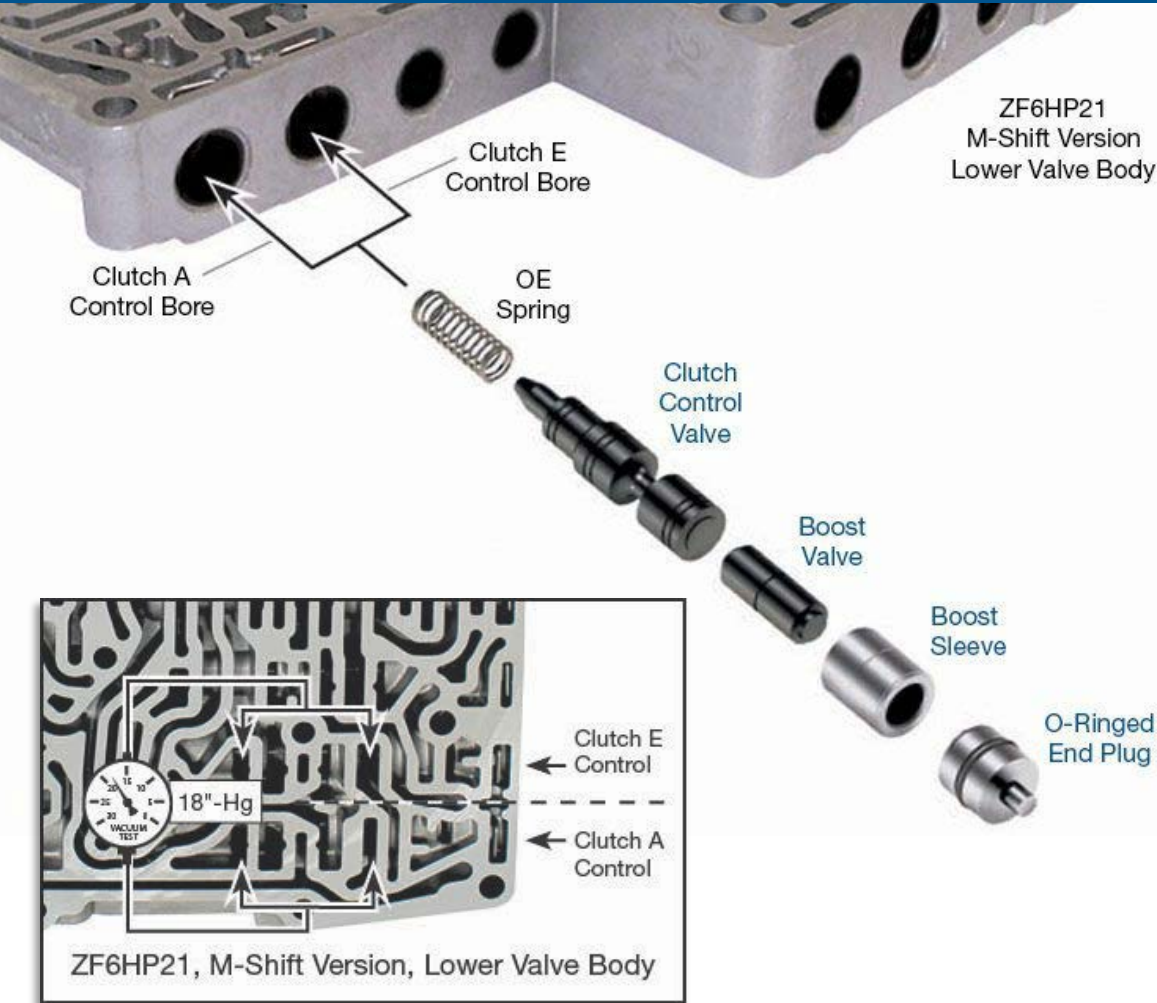

## Symptoms:

- Coastdown Neutral
- Flare shifts & bind-ups
- Harsh downshifts
- Pressure control out-of-range codes

## 95740-66K Oversized Clutch A & Clutch E Control Valve Kit:

- Valves are hard-coat anodized to reduce wear
- Sleeve is made from highly wear-resistant aluminum
- O-ringed end plug for better sealing

# A and E Clutch Control

Gen. 2 (E-Shift)

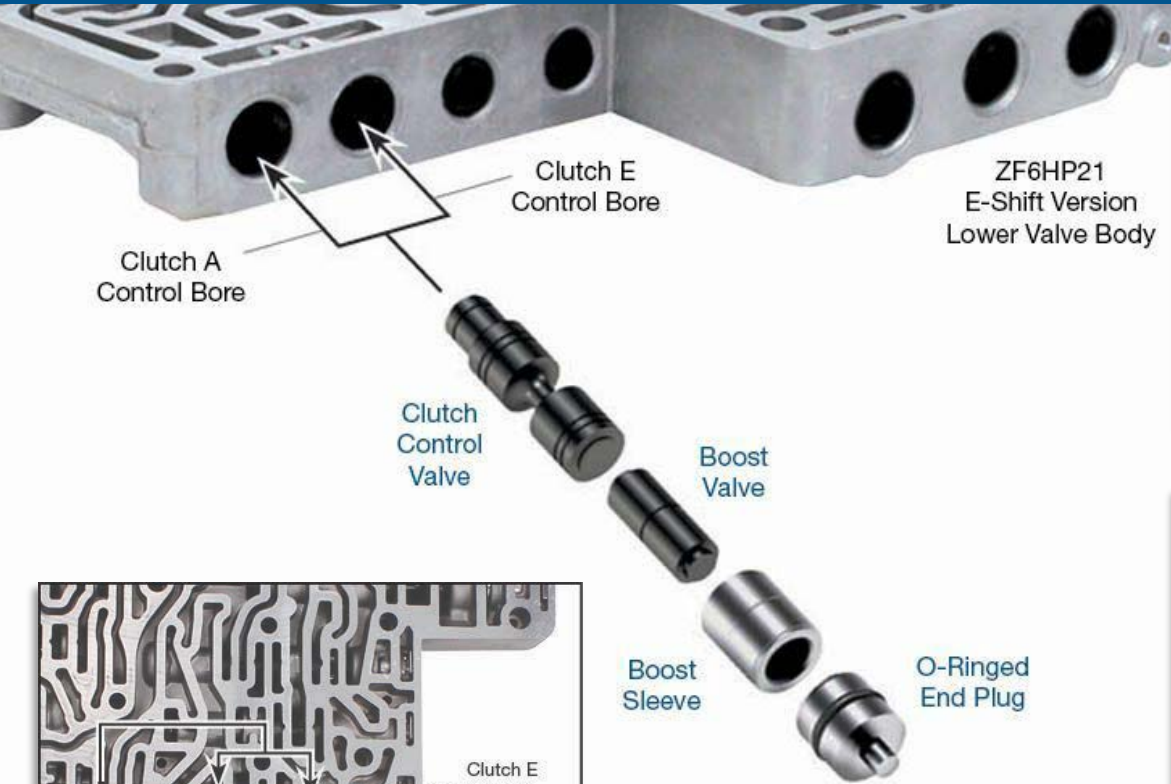

Symptoms:

- Coastdown Neutral
- Downshift bind-ups
- Flare shifts
- Harsh downshifts
- Pressure control out-of-range codes

95740-72K

Oversized Clutch A & Clutch E Control Valve Kit:

- Valves are hard-coat anodized to reduce wear
- Sleeve is made from highly wear-resistant aluminum
- O-ringed end plug for better sealing

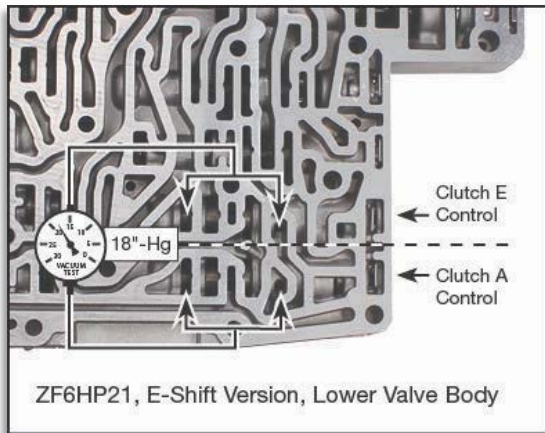

# Converter Clutch Release Regulator

Gen. 2 (E-Shift)



ZF6HP19 Lower Valve Body

- Symptoms:
- Excess TCC slip RPM & related codes
  - Low TCC release pressure
  - Flare shifts
  - Overheated converter
  - Harsh downshifts
  - Rough idle in Reverse
  - Harsh TCC apply & release

95740-05K  
Oversized Converter Release Regulator Valve Kit:

- Valve is hard-coat anodized to reduce wear
- The tuned spring included maintains OE operating pressures with the new oversized valve

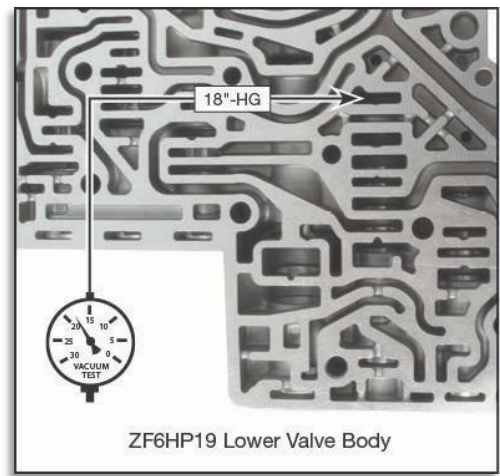

# Spacer Plate Identification

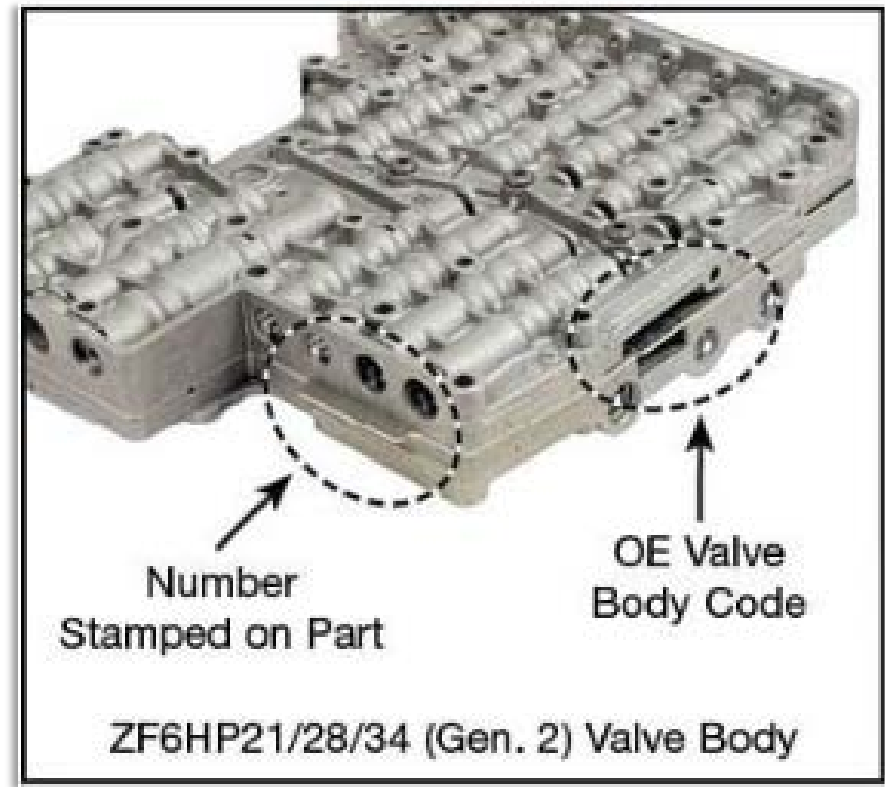
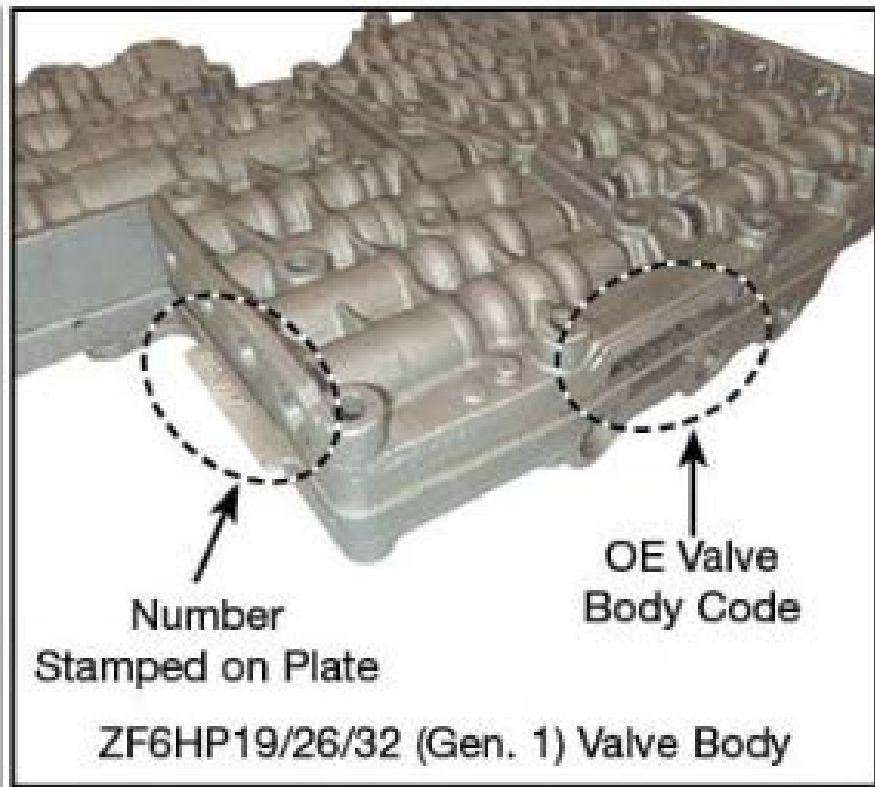



# Spacer Plate Applications

OE Valve Body Code	Number Stamped on Original Plate	Sonnax Part Number	Valve Body Generation
<b>E510F</b>	6L2P-7Z490-FC or 6L2P-7Z490-FB	95740-510	Ford 6R60
<b>A035/B035</b>	1068-327-141	95740-035	ZF6HP19/26/32 (Gen. 1)
<b>A036/B036</b>	1068-327-145	95740-051	
<b>A046/B046</b>	1068-327-162	95740-046	
<b>A047/B047</b>	1068-327-163	95740-047	
<b>A051/B051</b>	1068-327-179	95740-051	
<b>A052/B052</b>	1068-327-180	95740-052	
<b>A053/B053</b>	1068-327-189	95740-053	
<b>A063/B063</b>	1068-327-210	95740-063	ZF6HP21/28/34 (Gen. 2)
<b>A065/B065</b>	1068-327-224	95740-065	

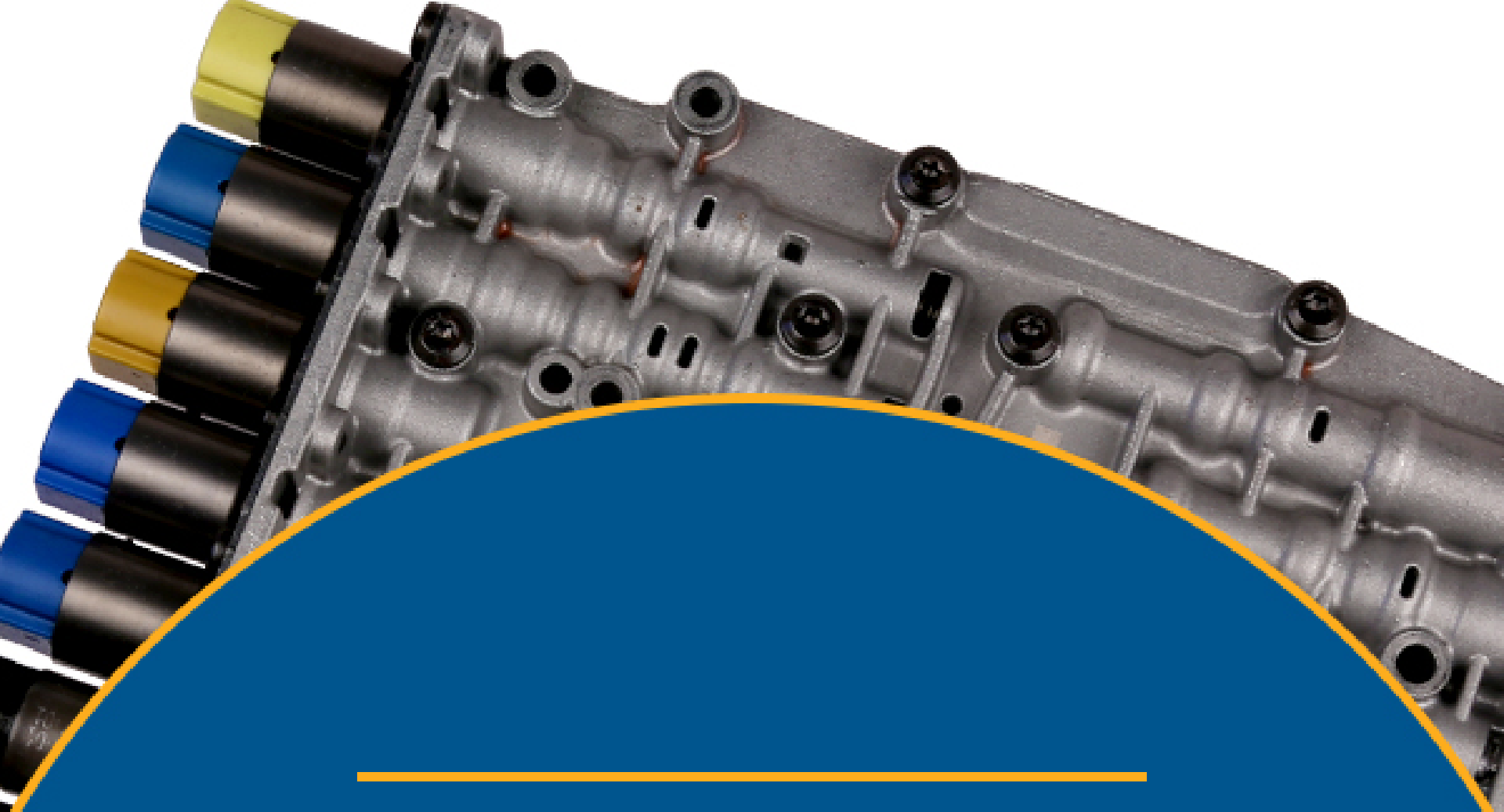

---

# Symptoms & Corrections

---

# Symptoms & Corrections

Symptoms	Corrections
Slip in Reverse, harsh Shifting once hot, 4-5 slip or flare	Valve body repair likely necessary.
Range codes, failsafe condition	Clean internal range sensor.
Erratic shifting	Low fluid level, which is one of the most common and overlooked issues on the 6HP. Check for OE reflash for various shift concerns.
3-4/4-3 Clutch squawk	Incorrect fluid, lack of friction modifier. Modifier # S671 090 288
Blown E clutch snap ring	Install updated E drum.
Loss of Park	Bent electronic shift linkage, also can be caused by incorrect emergency cable adjustment.
TCC shudder or RPM swing	Incorrect type of fluid. Must flush complete and possibly multiple times. Lockup clutch de-bonding issue. O-ring on the converter piston id. leaking. Incorrect converter damper not matched to the engine. Incorrect TCC friction material. Check for possible reflash.
Immediate failsafe after mechatronic or VB service	Chassis harness to case connector is not fully engaged.

# Symptoms & Corrections

Symptoms	Corrections
Limited vehicle speed (not exceeding 13 km/8 mph)	Mechatronic not programmed to the vehicle.
Moan or growl noise on coast down shifts	Possible internal driveline issues, such as bushings or bearings.
Early downshifts	Check engine performance first.
No engagement, Forward or Reverse	Battery and alternator voltage less than 9.0 volts or more than 16 volts causes erratic trans control.
3rd or 5th failsafe/default mode	TCM temperature out of range can create this. Check cooler and air flow.
Harsh shifts	Possible trans. fluid temperature sensor or solenoid out of range. Two temperature sensors on TCM. One for trans. temp. and one for TCM temp. If either goes over 170C /338F, trans. & TCM will shut down.
Engine will not crank	Defective park neutral switch.
Transmission will not adapt, may operate at maximum line pressure, no clutch actuation, MIL on	Solenoid circuit problem.

# Symptoms & Corrections

Symptoms	Corrections
No upshift, maximum line pressure	Possible bad ground, stuck valves or N/P switch failed.
Poor 3-2, 2-1 shifts, slip, flare, possible slip/ratio DTC's	Inspect the MAF sensor and air intake for issues. Inspect the intake air duct for cracks as well as being correctly attached to the throttle body.
Intermittent Neutral during a shift	Spark plug misfire causing EMI problems. This can interfere with the TP values leading to the complaints. Replace the spark plugs.
No upshift after a downshift.	This transmission application software utilizes an operational mode known as "Corner Detection." This mode uses the front wheel speed sensors as an input to determine when this mode should be active. Variation in "tire rollout" (1 KPH is all that is needed) caused by tire size differences or tire pressure differences from side-to-side can lead to this issue.

# Additional Resources

- **FREE Online Sonnax Tech Resources**  
**[www.sonnax.com](http://www.sonnax.com)**
- **Sonnax Tech Support**  
**(800) 843-2600 or**  
**(802) 463-9722 ext. 398**  
8:30 a.m. to 7:00 p.m. ET, Mon - Fri  
**[sonnaxtechsupport@sonnax.com](mailto:sonnaxtechsupport@sonnax.com)**

Thank You  
QUESTIONS?



# Become a Sonnax Insider Today!

## ➤ **Get the scoop on all new Sonnax products.**

- Whether it's a high-demand part, all-inclusive kit, or innovative tool, you'll be the first to know when it's available.

## ➤ **Discover expert Sonnax technical resources.**

- Learn cutting-edge rebuilding tips and tricks from the pros, find out how to solve everyday transmission problems and hone your troubleshooting skills.

## ➤ **Stay up-to-date on industry trends and events.**

- From essential news and industry trends to special upcoming tradeshow and seminars, trust Sonnax to keep you in the loop.

