



FREE

sonnax®
WEBINAR

Dodge TorqueFlite® 8 (ZF8)
2015 Challenger Intro & Theory of Operation

ZF8 Webinar Series Part 1 of 2

WELCOME

- **Connections**
- **Handout**
- **Questions**
- **jad@sonnax.com**

FREE Online Sonnax Tech Resources

www.sonnax.com

Tech Articles • Vacuum Test Guides • Valve Body Layouts • Videos & More

Sonnax Tech Support

Call: (800) 843-2600 or +1 (802) 463-0288

8:30 a.m. to 7:00 p.m. ET, Mon. – Fri.

Email: sonnaxtechsupport@sonnax.com



2015 Dodge Challenger
SXT Plus
Features & Specifications

Engine & Transmission Specifications

2015 Dodge Challenger SXT Plus Features & Specifications

- 3.6 V-6 and 8-speed = 19/31 mpg.
- The change from 5-speed (722.6) to 8-speed brings fuel efficiency up 15%.

Engine Specs

- 3.6L 24-Valve V-6 with VVT
- 305 HP 268 ft-lbs. of torque

Transmission Specs/Ratios

- TorqueFlite 8-speed automatic
- 845RE also known as ZF8HP45
- Built in Kokomo, Ind.



Transmission Ratios

Differential Ratio

3.07:1

1 st Gear	2 nd Gear	3 rd Gear	4 th Gear	5 th Gear	6 th Gear	7 th Gear	8 th Gear	Reverse
4.71	3.14	2.10	1.67	1.29	1.00	.084	.067	3.30

Keyless Entry & Ignition

2015 Dodge Challenger SXT Plus Features & Specifications

Entry of the vehicle requires the FOB to be close by.

Simply put your hand under the door handle and the locks go up.

Key FOB



Ignition



Shifter Information & Available Ranges

2015 Dodge Challenger SXT Plus Features & Specifications

Slide shifter to the left for Manual mode, then toggle shifter + or -



- Downshift

Manual

+ Upshift



Park

Reverse

Neutral

Automatic shifts

Drive



Manual Park release is located ender tray.

Reverse

2015 Dodge Challenger SXT Plus Features & Specifications

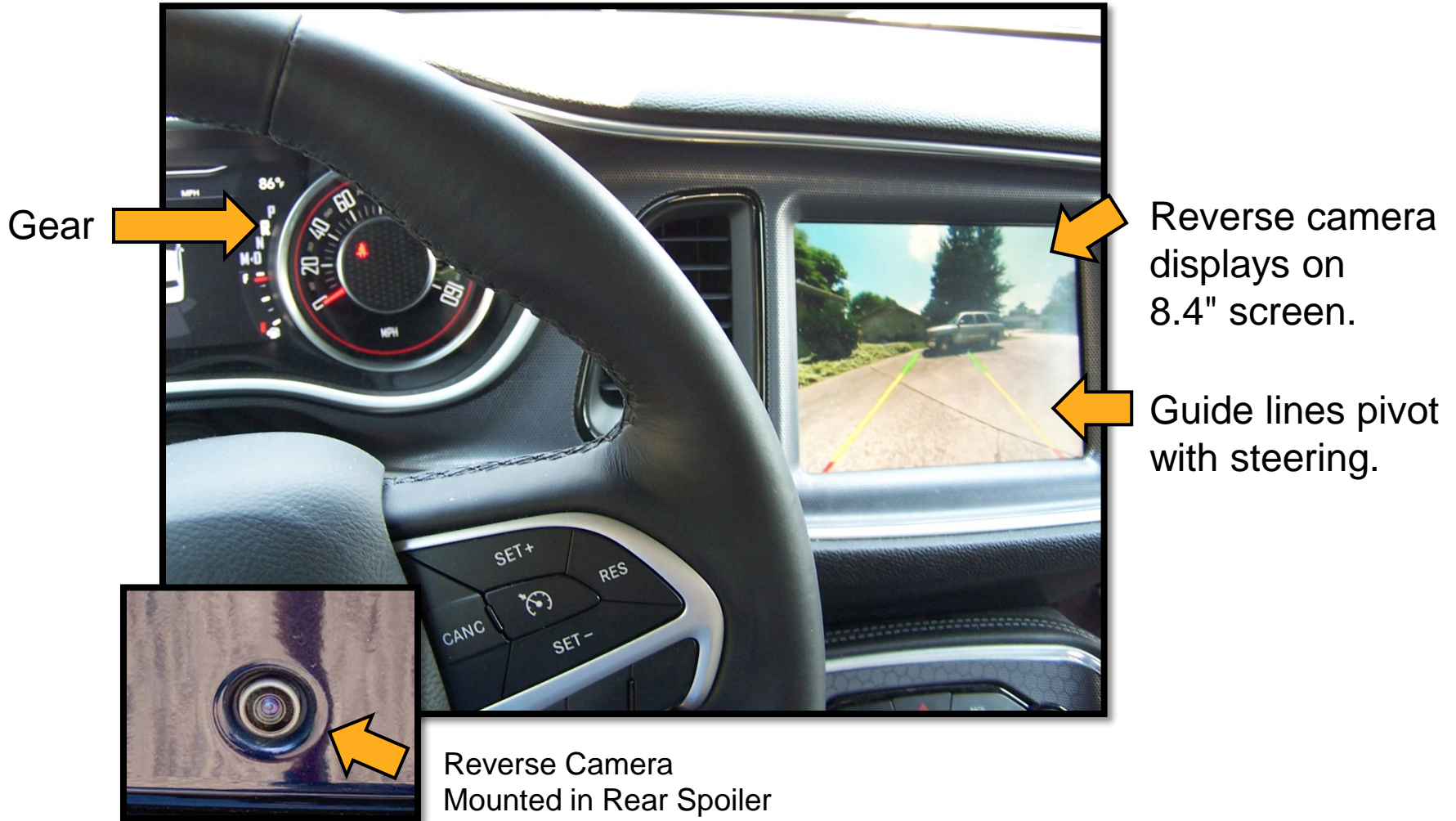

Drive & Manual Mode

2015 Dodge Challenger SXT Plus Features & Specifications



“D” Position

In the Drive position, 1st through 8th gears are automatically shifted.

NOTE: When downshifting to a stop, 1st gear will only be available at 0 mph, otherwise it will take off in 2nd.



“M” Position

In the Manual position, 1st through 8th gears can be selected.

NOTE: It will not shift unless you select it! RPM will go on rev limiter! You cannot upshift past 2nd gear at a stop. "Shift Not Allowed" will appear if an upshift or downshift is selected that is out of RPM range.

Sport Mode

2015 Dodge Challenger SXT Plus Features & Specifications



- When the Sport Mode button is selected, a flag will illuminate on the dash display. Shift scheduling will be delayed and the shifts will be firmer than in regular Drive Mode.
- Sport Mode also can be selected in Manual shift mode, which also firms shifts.

NOTE: Shift timing is related to how quickly the throttle is depressed and is extremely sensitive in Sport Mode.

Shift Point Timing in "D" & Sport Mode

2015 Dodge Challenger SXT Plus Features & Specifications

"D" Position: Light Throttle

- 1-2 upshift at 12 mph
- 2-3 upshift at 19 mph
- 3-4 upshift at 27 mph
- 4-5 upshift at 32 mph
- 5-6 upshift at 40 mph
- 6-7 upshift at 45 mph
- 7-8 upshift at 49 mph

NOTE: Shift timing is quick on light throttle and **TCC** is applied right after launch. Shift calibration is quick, but there is no noticeable loss of power or sensation of the vehicle falling on its face. Any throttle tip-in gives a quick downshift to the appropriate gear.

"D" Position with Sport Mode: Light to Medium Throttle

- 1-2 upshift at 23 mph
- 2-3 upshift at 33 mph
- 3-4 upshift at 47 mph
- 4-5 upshift at 55 mph
- 5-6 upshift at 67 mph
- 6-7 upshift at 78+ mph
- 7-8 upshift at 88+ mph

NOTE: Shift timing is spread out on light-to-medium throttle and **TCC** is applied right after launch. Any throttle tip-in gives a quick downshift to the appropriate gear. Upshifts from a passing gear will be slightly delayed during the next upshift.

"D" Position: Shift Schedule Changes Based on Road Conditions

Upshift and downshift scheduling is dependent on road ascending/descending. The TCU also varies shifts based on ABS input for cornering.

Shift Point Timing in "D" – Cold Weather

2015 Dodge Challenger SXT Plus Features & Specifications

“D” Position: Light Throttle, Cold Weather

- 1-2 upshift at 18 mph
- 2-3 upshift at 23 mph
- Other shifts follow with a small delay in timing

NOTE: Shift timing is slightly delayed when fluid temp is cold for quick engine warm up. This strategy typically lasts for two shift cycles and then goes back to normal shift timing.

“D” Position: Light Throttle, Cold Weather Below 30°

- 1-2 upshift at 18 mph
- 2-3 upshift at 23 mph
- Other shifts follow with a small delay in timing

NOTE: Shift timing is slightly delayed when fluid temp is cold for quick engine warm up. The 1-2 has a considerable flare on it with temp below 30°F. **This is a programming issue.** This strategy typically lasts for two shift cycles and then goes back to normal shift timing.

Other Features & Settings

2015 Dodge Challenger SXT Plus Features & Specifications

Select "Controls" on display, then select "Settings."



Select "Safety & Driving Assistance."



Other Features & Settings

2015 Dodge Challenger SXT Plus Features & Specifications

"Hill Start Assist" can be toggled on or off.

NOTE: This is a function of the ABS when the vehicle is stopped on a slope. The brakes will be clamped for 1 to 3 seconds waiting on throttle signal increase after brake pedal is released.



Other Features & Settings

2015 Dodge Challenger SXT Plus Features & Specifications

0–60 Times are typically 6–6.3 seconds and 14.8 quarter at 94.8 mph.



Uconnect® Safety Recall R40

2015 Dodge Challenger SXT Plus Features & Specifications

Uconnect Safety Recall R40 (to prevent ABS and vehicle control externally) was sent in the mail with a one-time use USB and instructional booklet as an option for installing. Customers also had the option of taking their vehicle to the local dealer to update the software.

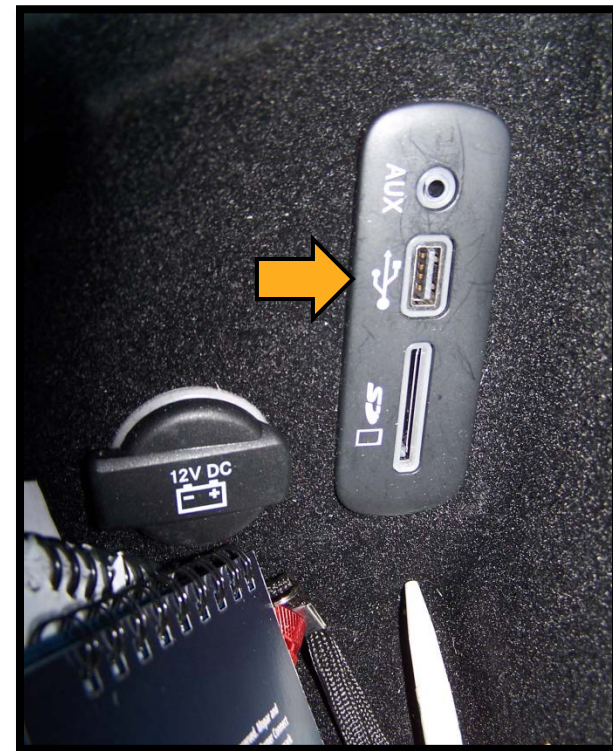
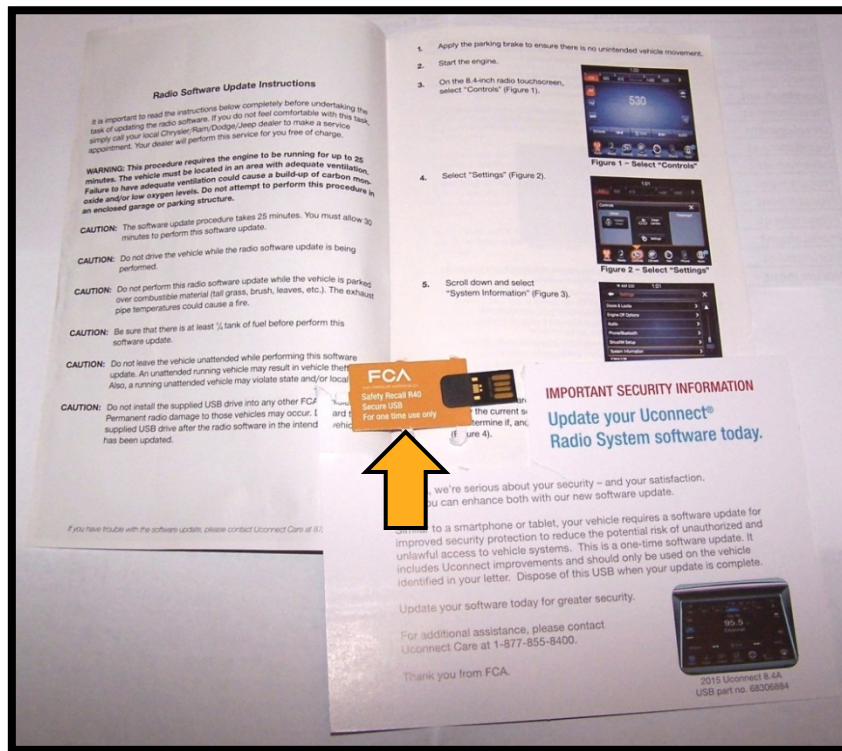



Dodge TorqueFlite[®] 8 (ZF8) Theory of Operation & VB Information

Clutch & Brake Operation

Dodge TorqueFlite® 8 (ZF8) Theory of Operation & VB Information

The TorqueFlite 8 provides eight Forward gears and Reverse through four planetary gear sets, two brakes and three clutch assemblies.

Gear	Brake A	Brake B	Clutch C	Clutch D	Clutch E
1 st	ON	ON	ON		
2 nd	ON	ON			ON
3 rd		ON	ON		ON
4 th		ON		ON	ON
5 th		ON	ON	ON	
6 th			ON	ON	ON
7 th	ON		ON	ON	
8 th	ON			ON	ON
R	ON	ON		ON	

Three-Path Torque Converter

Dodge TorqueFlite® 8 (ZF8) Theory of Operation & VB Information

The torque converter utilizes a torsional turbine dampener that helps limit vibration, especially with low RPM torque converter clutch apply. It also has a multi-plate torque converter clutch assembly.

This clutch is fully lockable and is applied at 14 mph, 40 RPM max slip.



NOTE: BMW application shown here.

Mechatronic Unit

Dodge TorqueFlite® 8 (ZF8) Theory of Operation & VB Information

- Made by Bosch and integrated with the valve body
- Connected to the CAN, Body Control Module and Shift by wire module
- Houses the input and output speed sensors and trans temp sensor
- Directly connects to all of the solenoids that control valve trains. Valve trains control gear changes via the brake and clutch assemblies

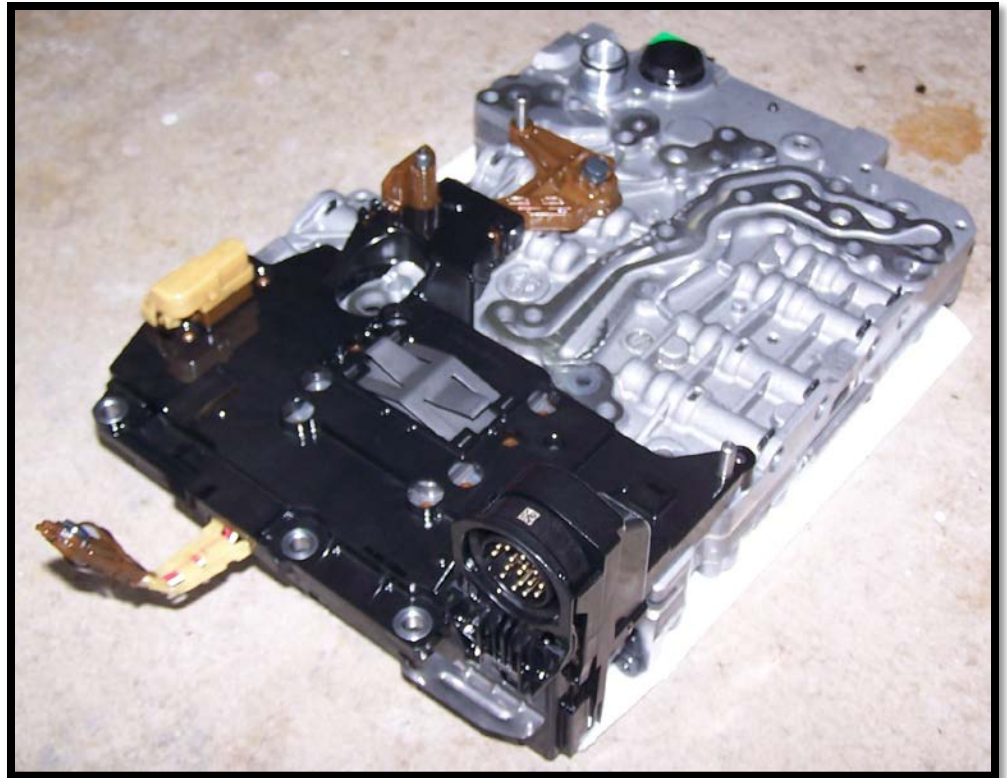



Unless otherwise indicated, the following valve body information is for ZF8HP45 and ZF8HP70 ONLY.

The Audi 8HP55 has similar valves, but they are found in different locations!

ZF8HP45/70 Upper VB Small Parts Locations

Sonnax Repair

1. 95740-15K

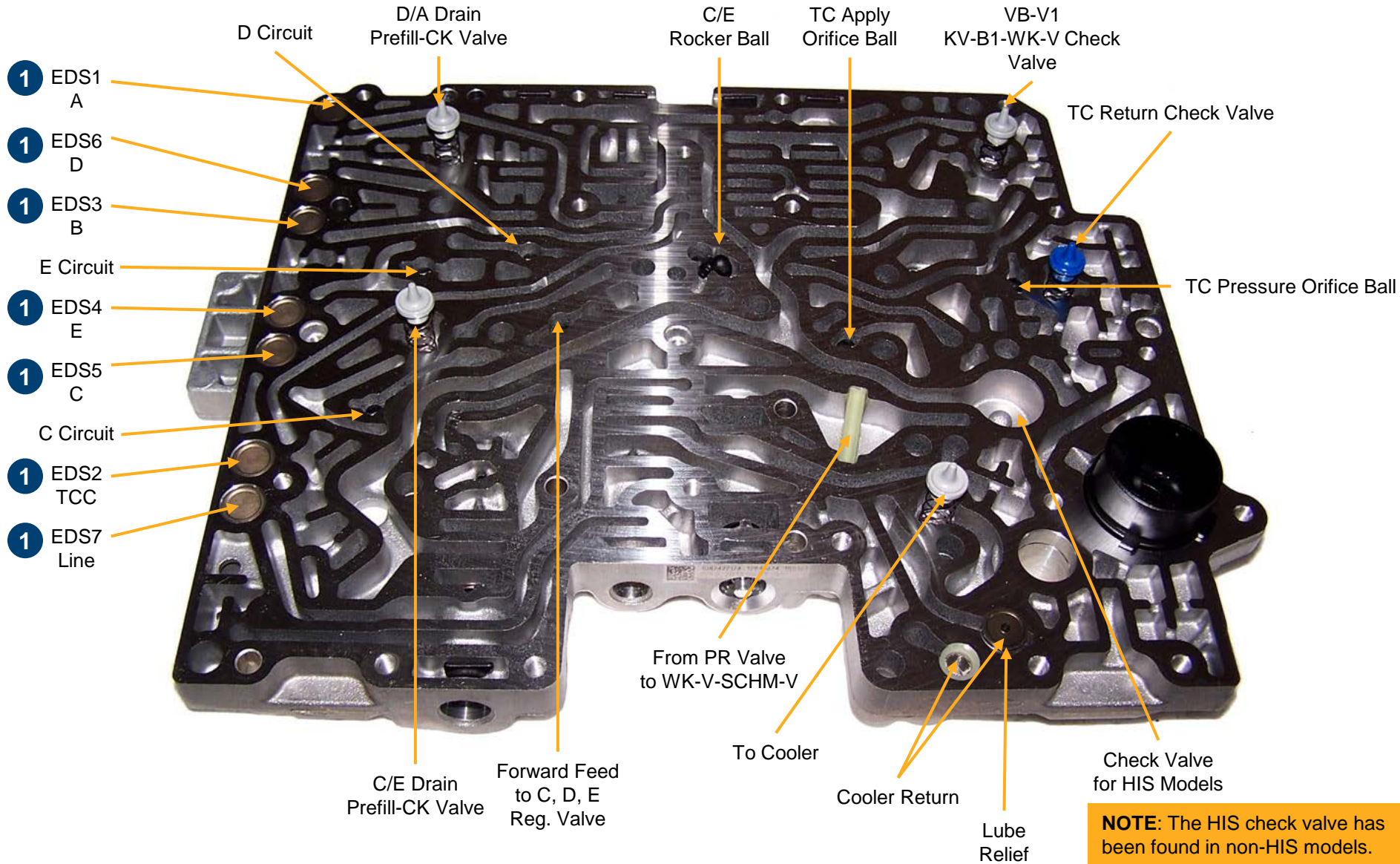

NOTE: The HIS check valve has been found in non-HIS models.

Sonnax Parts for Repair

Find full part details at www.sonnax.com.

Name	Part No.	Details	Reaming Required?	Tooling/Fixture Required
Accumulator Piston Kit Fits: <ul style="list-style-type: none">• ZF6HP19/26/32 (Gen. 1)• ZF6HP21/28/34 (Gen. 2)• ZF8HP45, ZF8HP55, ZF8HP70• Ford 6R60, 6R75, 6R80	95740-15K	Fits multiple locations	No	None

ZF8HP45/70 Upper VB Valve Locations

Sonnax Repairs

1. 35740-22

2. 35740-20K

ZF Nomenclature = Black

Chrysler Nomenclature = Red



- HV-B2
HV-B2
- 1 KV-B2
CV-B2/
B Clutch NIC
- 2 HV-A
HV-A
- 2 HV-D
HV-D

- WD-V
TC-V

- POS-V
POSD-V

Sonnax Parts for Repair

Find full part details at www.sonnax.com.

Name	Part No.	Details	Reaming Required?	Tooling/Fixture Required
Oversized B2 Clutch NIC Regulator Valve Fits ZF8HP45, ZF8HP55, ZF8HP70	35740-22		Yes	F-35740-TL22 & VB-FIX
Oversized Clutch Holding Valve Kit Fits ZF8HP45, ZF8HP55, ZF8HP70	35740-20K	Fits any of five locations	Yes	F-35740-TL20 & VB-FIX

1. 35740-30K
End Plug Repair
2. 35740-18K

ZF Nomenclature = Black
Chrysler Nomenclature = Red

Wear in this bore has caused dragging/bumpy downshift complaints and may be due to the TCC clutch not releasing quickly enough.



Anodizing coming off the OE valve.

WD-V 1 2
TC-V

Sonnax Parts for Repair

Find full part details at www.sonnax.com.

Name	Part No.	Details	Reaming Required?	Tooling/Fixture Required
Oversized TC Pressure Valve Kit Fits ZF8HP45, ZF8HP55, ZF8HP70	35740-18K		Yes	F-35740-TL5 & VB-FIX
O-Ringed End Plug Kit Fits ZF8HP45, ZF8HP55, ZF8HP70	35740-30K	Internal end plugs (8) & 13mm end plugs (3)	No	None

ZF8 TCC Diagnostics

TCC diagnosis can be performed with a capable scan tool and a pressure gauge on the PZT pressure tap. This pressure tap is connected to the converter charge circuit. PZT pressure in "D" at a stop is approximately 30 psi. PZT pressure drops to 20 psi at 14 mph in 1st gear, when TCC is applied. PZT pressure will increase slightly with higher throttle input and engine load.

NOTE: The TCC does not come back off fully until vehicle speed is below 14 mph. Wear in the converter charge valve may cause slow TCC release or a dragging sensation resulting in a bumpy downshift/release.

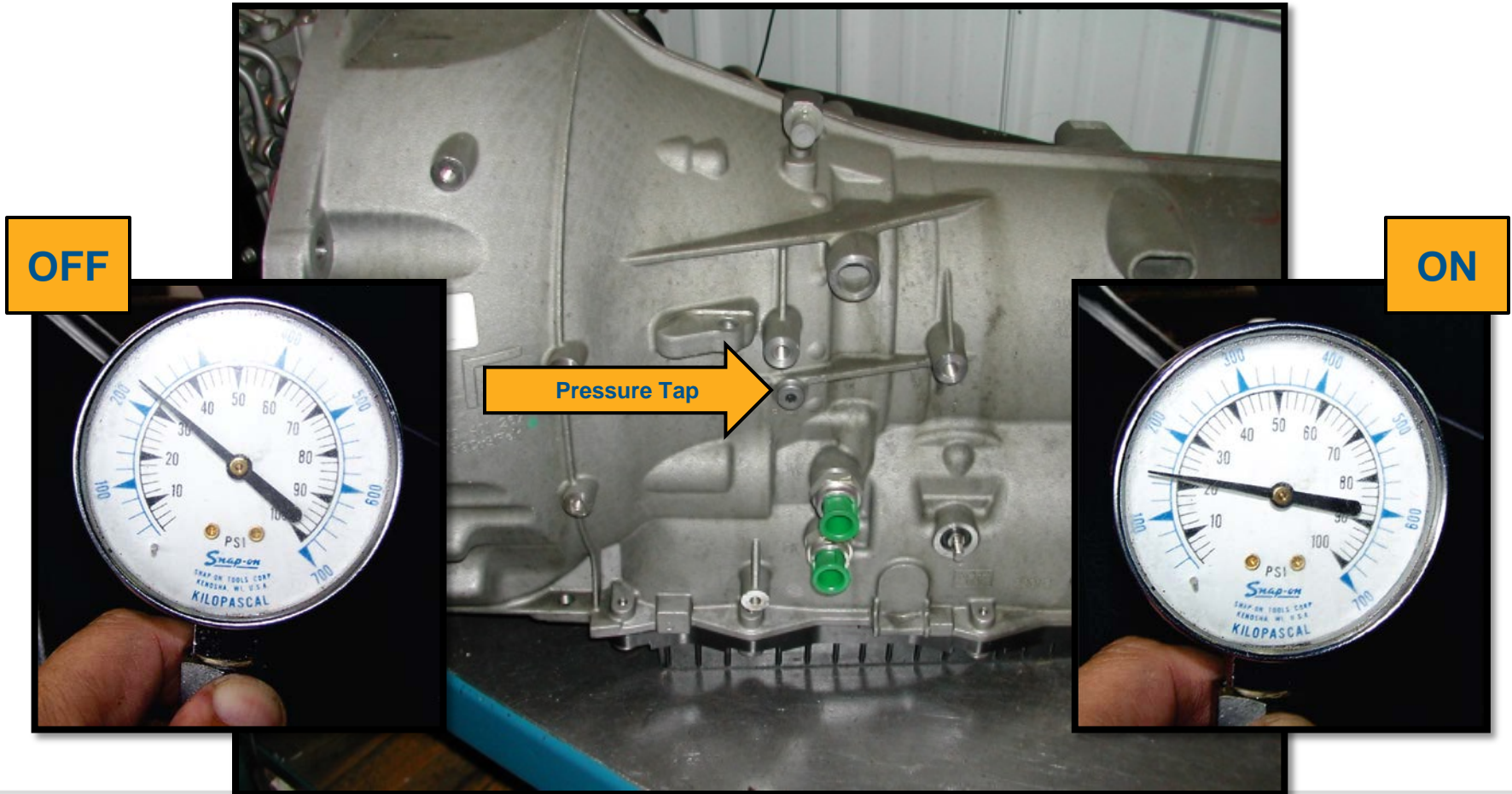

ZF8 Converter & TC Apply Circuit

1st Gear TC On (Partial to Full)

Pressure based on p_zT port, pressure will vary based on throttle increase.

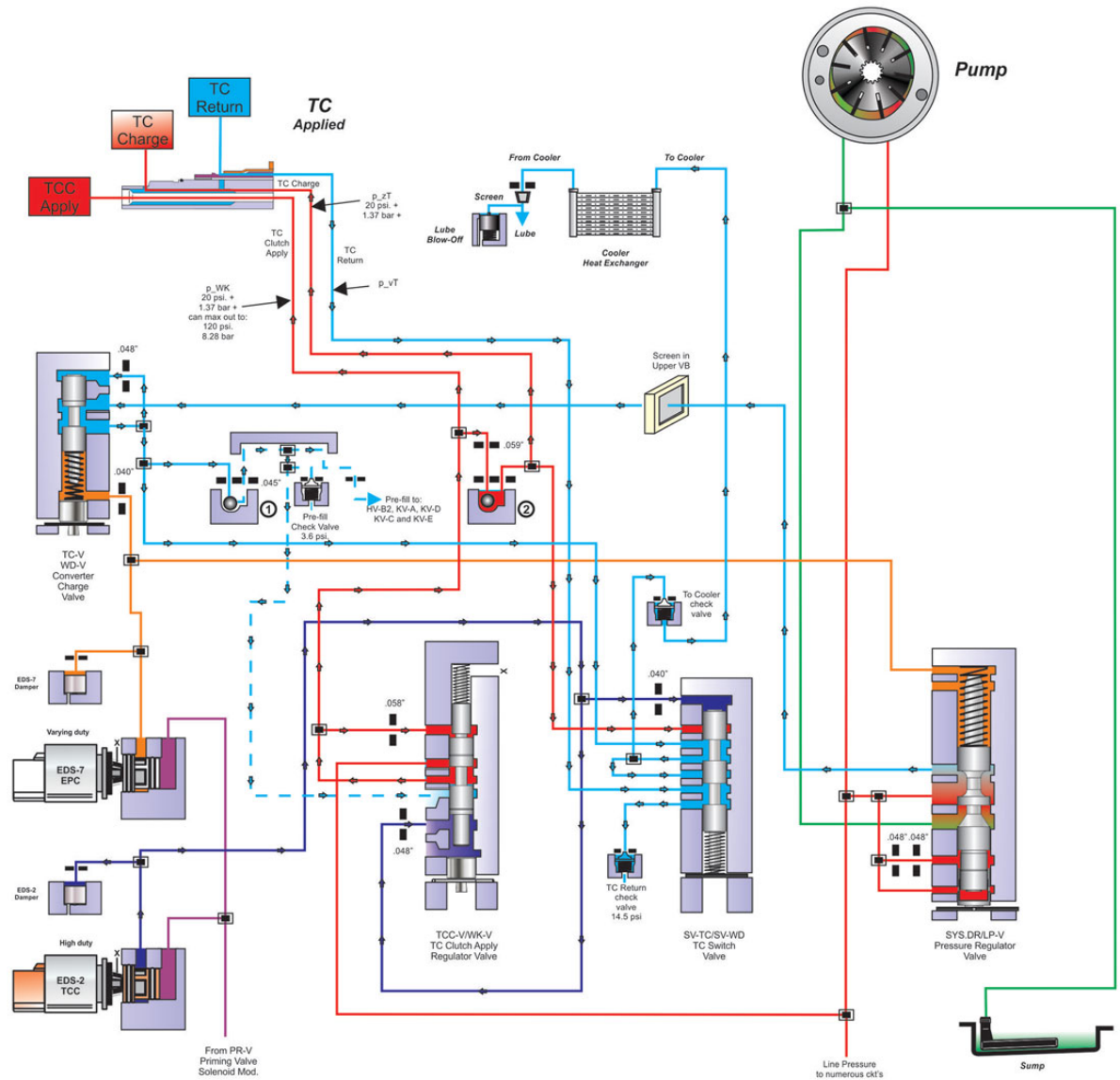

Separator plate is the same on both ZF8HP45 and ZF8HP70.

- 048 ZF8HP45/70 HIS and non-HIS E-shift model ZF part number stamped on plate = **1087 327 175 ZFS**
- OE valve body codes = **A048** or **B048**

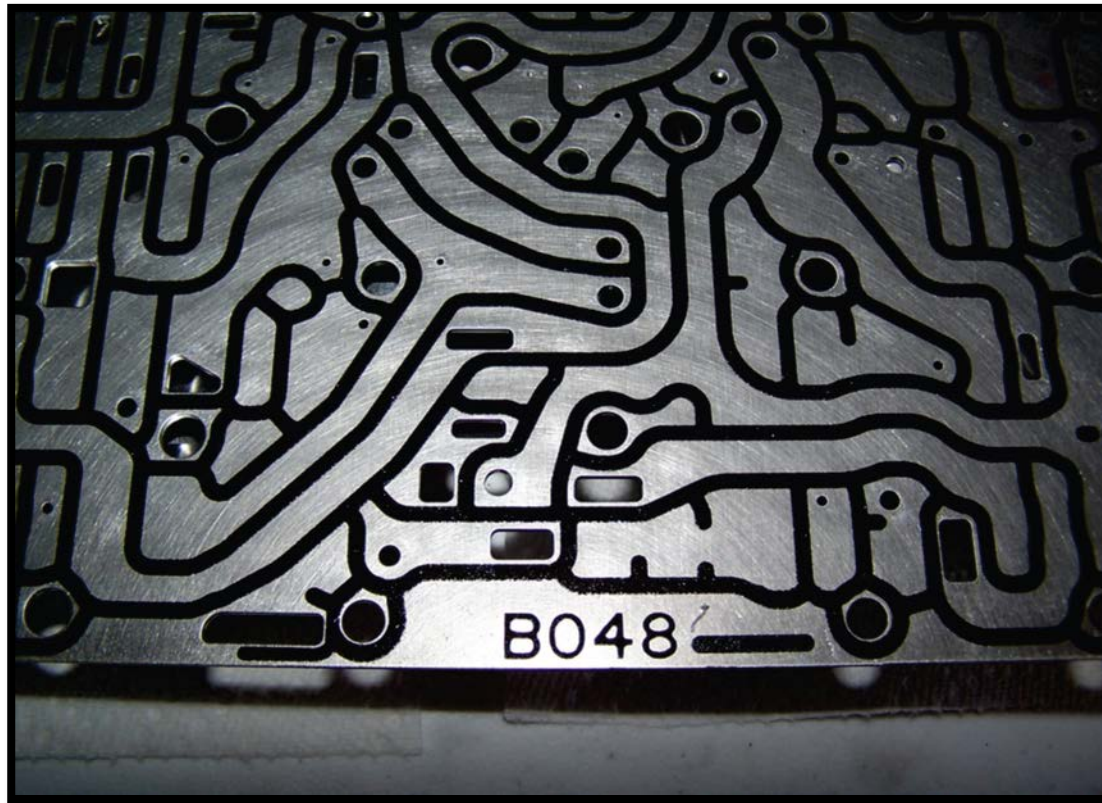

Sonnax Parts for Repair

Find full part details at www.sonnax.com.

Name	Part No.	Details	Reaming Required?	Tooling/Fixture Required
Valve Body Separator Plate Fits ZF8HP45, ZF8HP70 with: <ul style="list-style-type: none">• OE Valve Body Codes A048 & B048• No. Stamped on OE Plate: 1087 327 175 ZFS	35740-048		No	None

ZF8HP45/70 Solenoid Locations & Clutch Control/Function

ZF Nomenclature = Black

Chrysler Nomenclature = Red

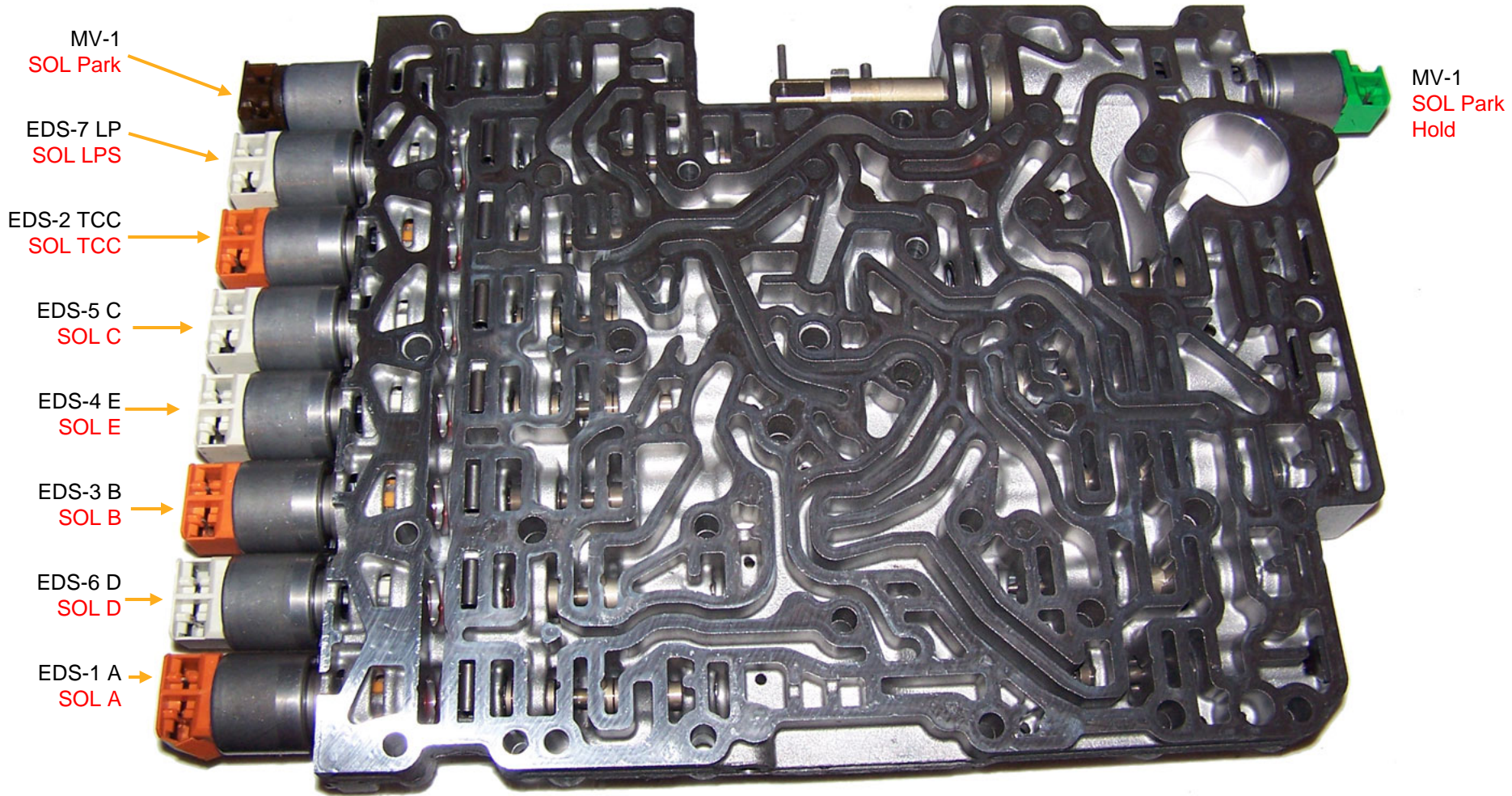

ZF8HP45/70 Pressure Control Solenoid Port Identification

Solenoid Ohm values are between 5 and 6 ohms based on temperature.

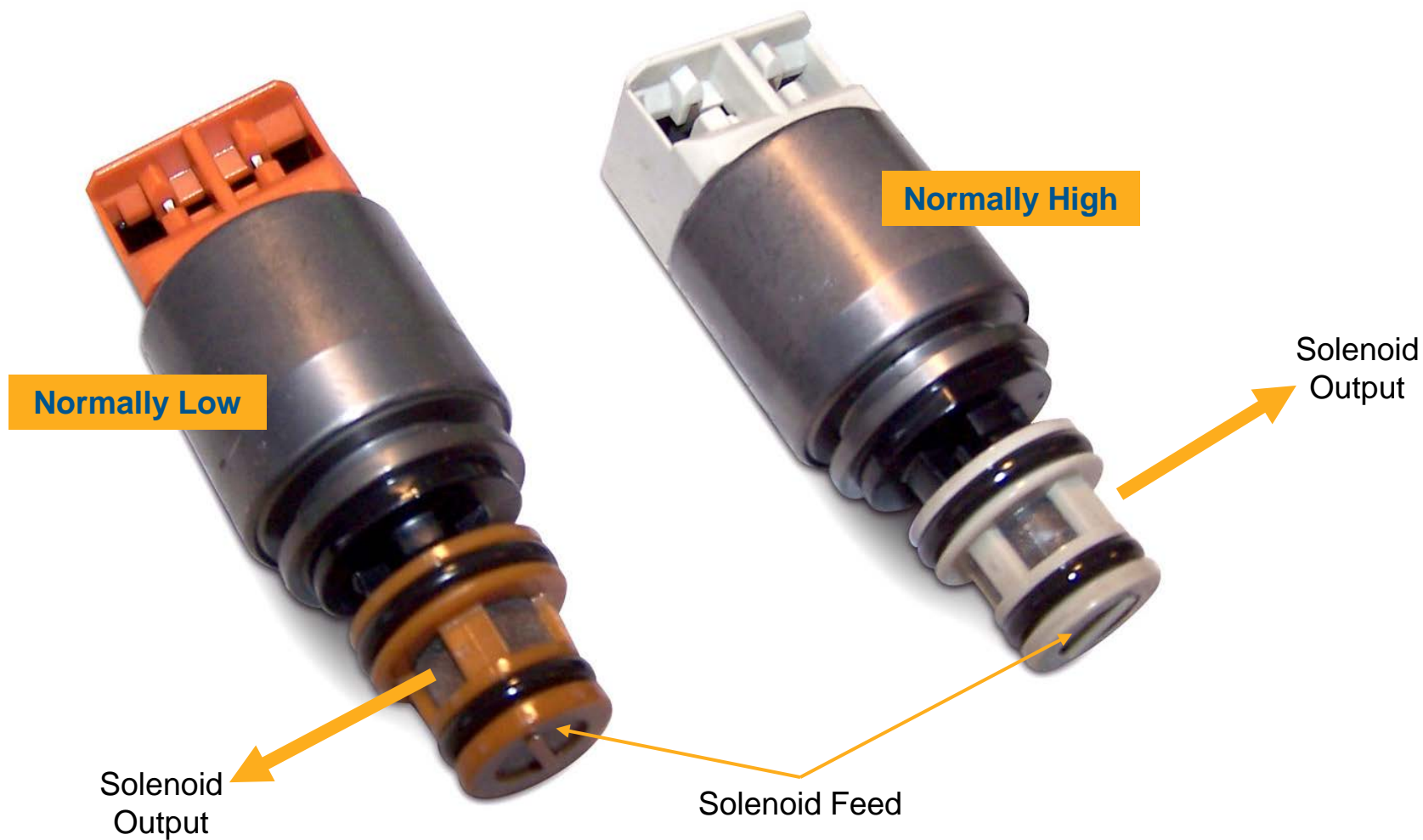

ZF8HP45/70 Lower VB Valve Locations – Rear Side

Sonnax Repairs

ZF Nomenclature = Black
 Chrysler Nomenclature = Red

1. 35740-30K
End Plug Repair
2. 35740-20K
3. 35740-21K



Sonnax Parts for Repair

Find full part details at www.sonnax.com.

Name	Part No.	Details	Reaming Required?	Tooling/Fixture Required
O-Ringed End Plug Kit Fits ZF8HP45, ZF8HP55, ZF8HP70	35740-30K	Internal end plugs (8) & 13mm end plugs (3)	No	None
Oversized Clutch Holding Valve Kit Fits ZF8HP45, ZF8HP55, ZF8HP70	35740-20K	Fits any of five locations	Yes	F-35740-TL20 & VB-FIX
Oversized Priming Valve Kit Fits ZF8HP45, ZF8HP55, ZF8HP70	35740-21K		Yes	F-35740-TL20 & VB-FIX

ZF8 Clutch Regulator & Holding Valve Theory of Operation

C Clutch Partial Hydraulic Circuit

- In 4th gear, the C clutch is OFF, TCC is ON.
- Pre-fill pressure is supplied to the C clutch apply circuit.

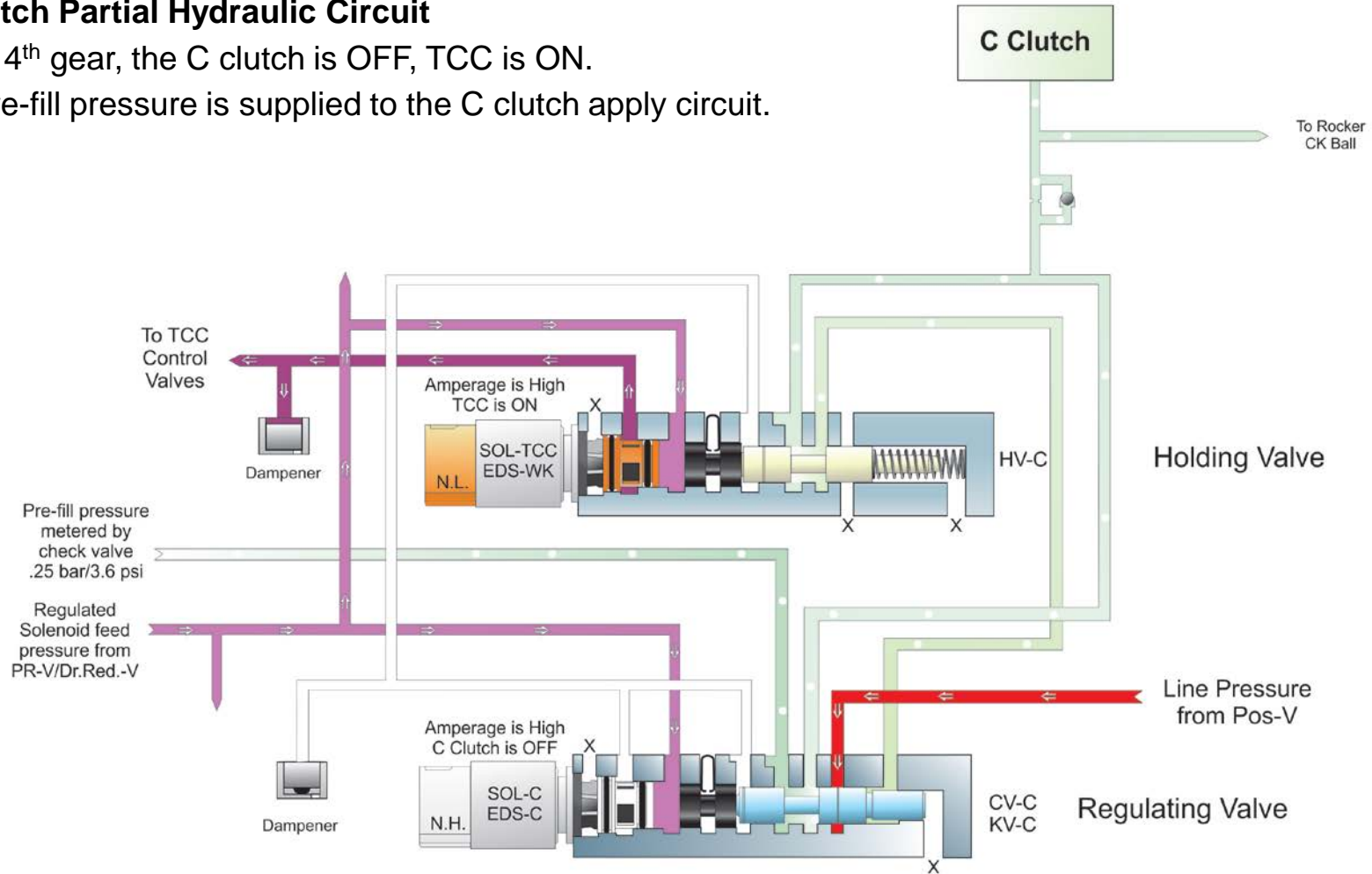

ZF8 Clutch Regulator & Holding Valve Theory of Operation

C Clutch Partial Hydraulic Circuit

- During the transition to 5th gear, C Clutch pressure is ramping up, TCC is partial.
- C Clutch apply pressure is regulated based on Sol-C output acting on HV-C and CV-C.

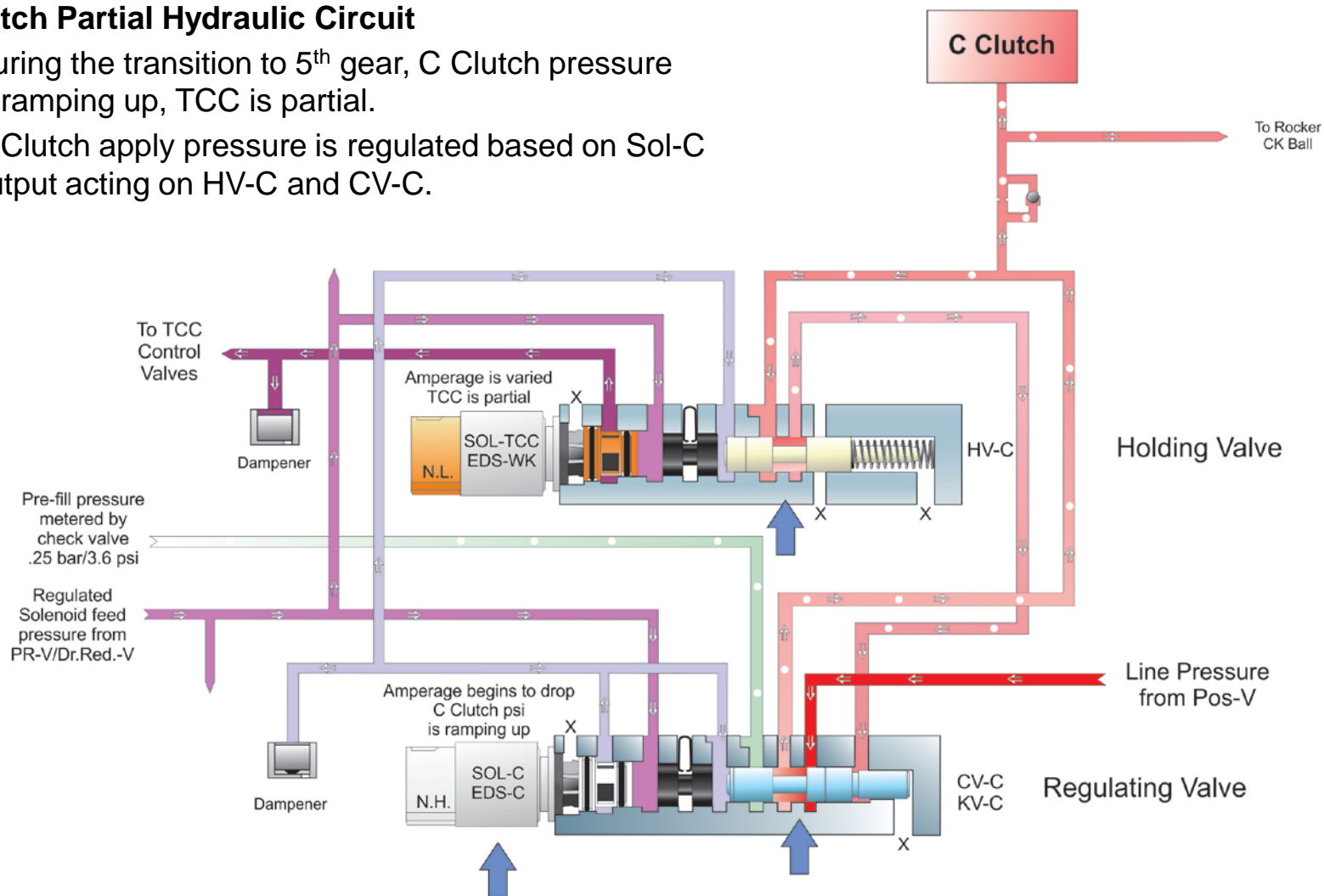

ZF8 Clutch Regulator & Holding Valve Theory of Operation

C Clutch Partial Hydraulic Circuit

- In 5th gear, C Clutch pressure is line pressure, TCC is ON.
- C Clutch apply pressure is line pressure, Sol-C amperage is low.

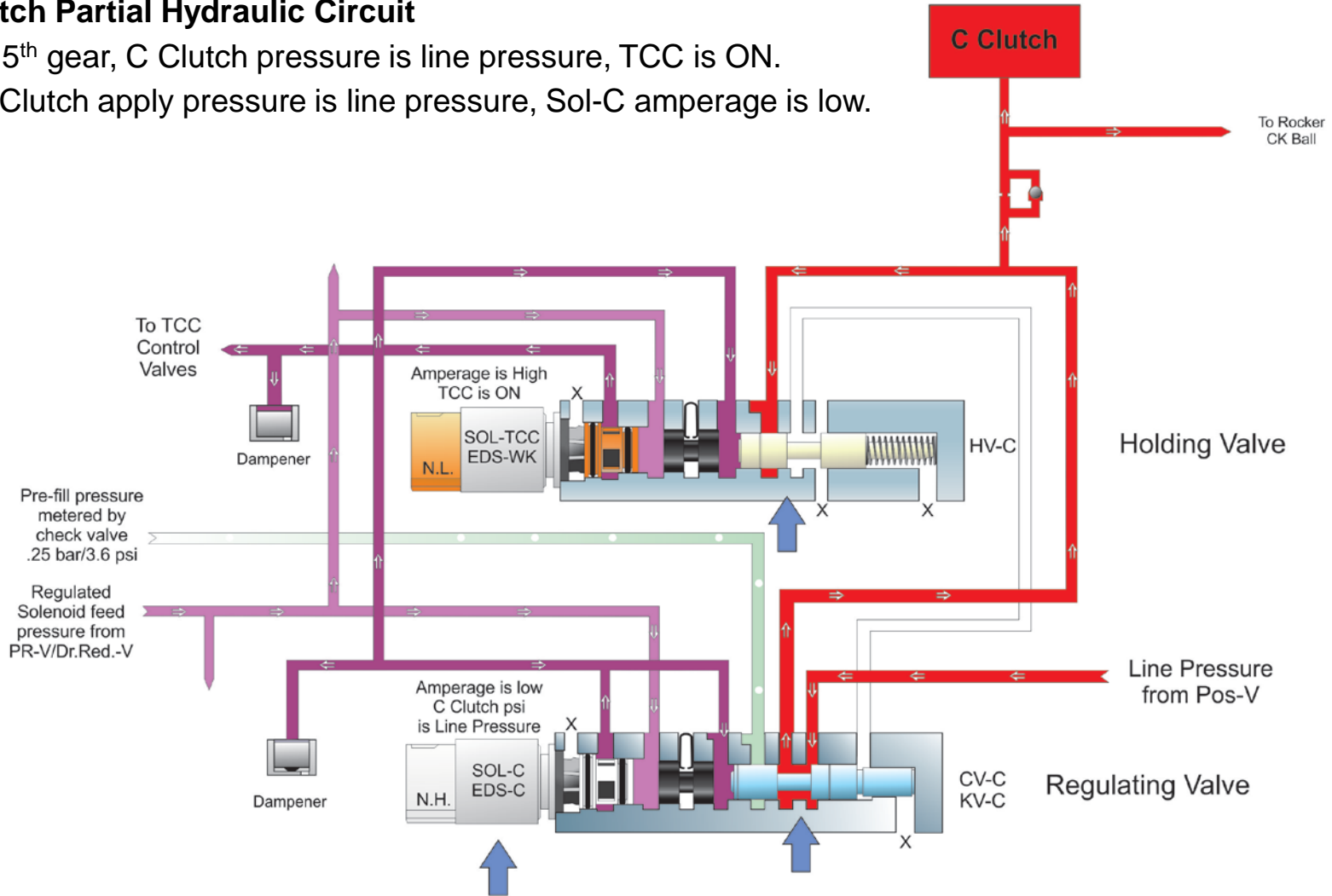

ZF8HP45/70 Lower VB Valve Locations – Front Side

ZF Nomenclature = Black
 Chrysler Nomenclature = Red

Sonnax Repairs

1. 35740-30K
End Plug Repair
2. 35740-03
3. 35740-01K
4. 35740-05
5. 35740-13K
6. 35740-20K

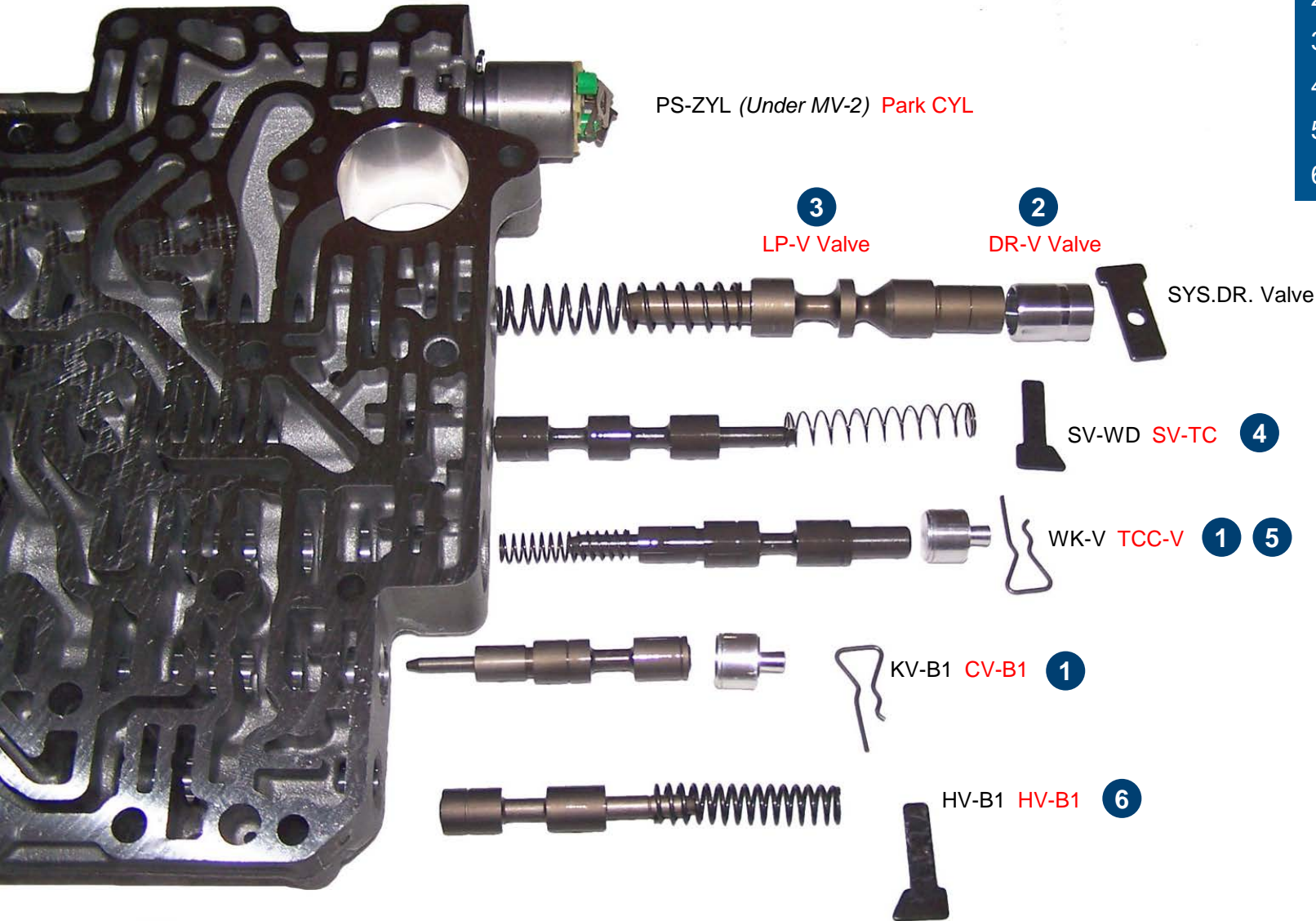

Sonnax Parts for Repair

Find full part details at www.sonnax.com.

Name	Part No.	Details	Reaming Required?	Tooling/Fixture Required
O-Ringed End Plug Kit Fits ZF8HP45, ZF8HP55, ZF8HP70	35740-30K	Internal end plugs (8) & 13mm end plugs (3)	No	None
Pressure Regulator Sleeve Fits ZF8HP45, ZF8HP55, ZF8HP70	35740-03		No	None
Oversized PR Valve Kit Fits ZF8HP45, ZF8HP55, ZF8HP70	35740-01K		Yes	F-35740-TL & VB-FIX
Oversized TC Switch Valve Fits ZF8HP45, ZF8HP55, ZF8HP70	35740-05		Yes	F-35740-TL5 & VB-FIX
Oversized Torque Converter Clutch Valve Kit Fits ZF8HP45, ZF8HP55, ZF8HP70	35740-13K		Yes	F-35740-TL13 & VB-FIX
Oversized Clutch Holding Valve Kit Fits ZF8HP45, ZF8HP55, ZF8HP70	35740-20K	Fits any of five locations	Yes	F-35740-TL20 & VB-FIX

ZF8HP45/70 VB-to-Case Passage Identification

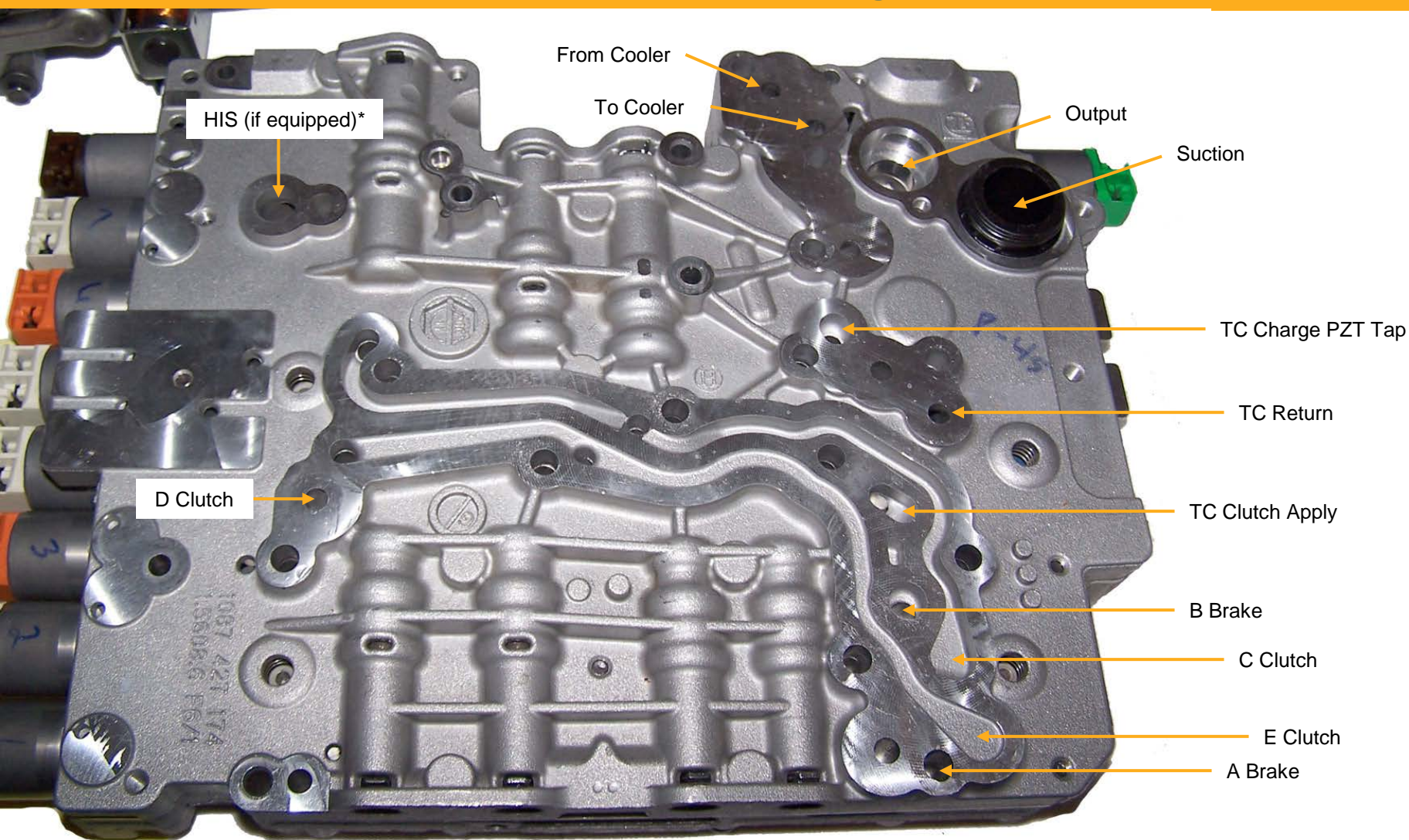

*HIS = Hydraulic Impulse Storage for stop-start function.

HIS (Hydraulic Impulse Storage)

Dodge TorqueFlite® 8 (ZF8) Theory of Operation & VB Information

HIS = Hydraulic Impulse Storage
for stop-start function (engine shutoff at stops).

The HIS is a storage device/accumulator that pressurizes clutch components for a quick startup when the brake is released, primarily before the pump is fully pressurized as the engine is restarted.

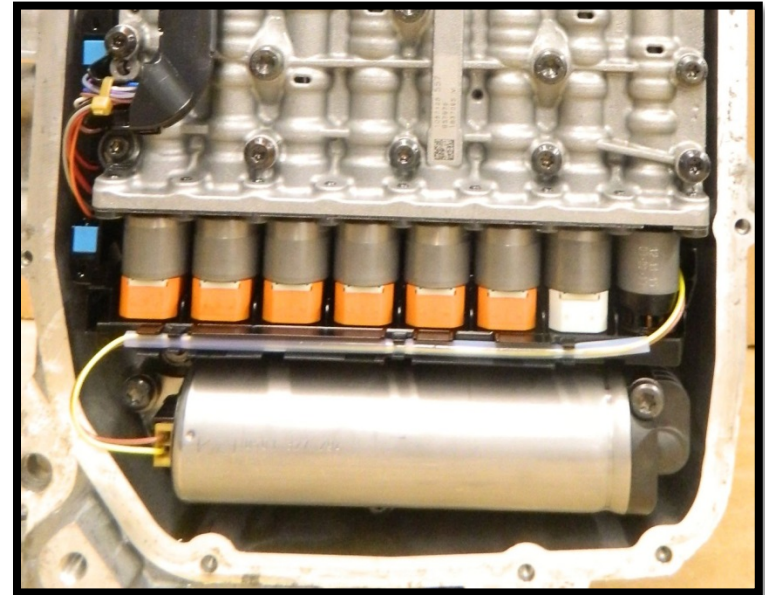

NOTE: Audi valve body shown here.

HIS (Hydraulic Impulse Storage)

Dodge TorqueFlite® 8 (ZF8) Theory of Operation & VB Information

HIS-type vehicles have an option to turn off the stop-start feature.

When the green light is on,
stop-start is operational.



Press button to turn off stop-start.



NOTE: 2016 Jeep Grand Cherokee shown here.

Drain & Fill (Lifetime Oil)

Dodge TorqueFlite® 8 (ZF8) Theory of Operation & VB Information

The red tag on the pan shows fluid type Mopar 6815795AA (green) and that fluid temp must be 122°F to check the level.

Dry fill is approximately 8.5 qts. / 8.0l.

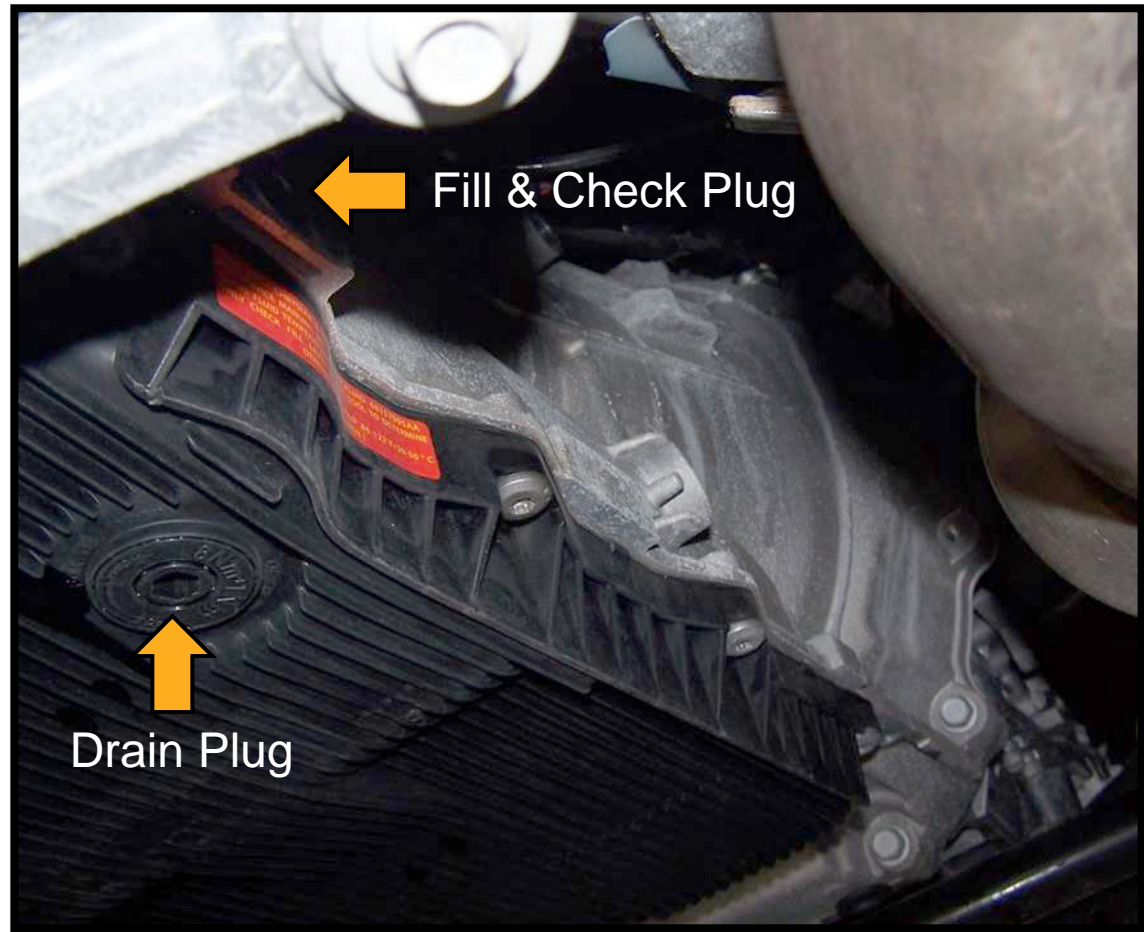



FREE

sonnax®
WEBINAR

Don't miss Part 2 of this webinar series on Aug. 23 & 24.

**A Look Inside Dodge TorqueFlite® 8 (ZF8)
Transmission & Torque Converter**

**Space is limited, register today at
www.sonnax.com/webinars.**

Additional Resources

FREE Online Sonnax Tech Resources

www.sonnax.com

Tech Articles • Vacuum Test Guides • Valve Body Layouts • Videos & More

Sonnax Tech Support

Call: [\(800\) 843-2600](tel:(800)843-2600) or [+1 \(802\) 463-0288](tel:+1(802)463-0288)

8:30 a.m. to 7:00 p.m. ET, Mon. – Fri.

Email: sonnaxtechsupport@sonnax.com

Thank You
QUESTIONS?



Become a Sonnax Insider TODAY!

➤ **Get the scoop on all new Sonnax products.**

Whether it's a high-demand part, all-inclusive kit, or innovative tool, you'll be the first to know when it's available.

➤ **Discover expert Sonnax technical resources.**

Learn cutting-edge rebuilding tips and tricks from the pros, find out how to solve everyday transmission problems and hone your troubleshooting skills.

➤ **Stay up-to-date on industry trends and events.**

From essential news and industry trends to special upcoming tradeshow and seminars, trust Sonnax to keep you in the loop.

